

# 3<sup>RD</sup> WAVE

ADVANCED WAVETABLE SYNTH



## KEYBOARD USER MANUAL



**The 3rd Wave Team**

Bob Coover, Andrew Silverman, Kevin Juszczuk, Tracy Wadley, Mark Wilcox, Ross Wilcox

**Sound Design**

Peter Dyer, Jorg Huttner, Kurt Kurasaki, Drew Neumann, Robert Rich,  
Matia Simovich, Huston Singletary, James Terris, Mark Wilcox, Bob Coover

# **3<sup>RD</sup> WAVE**

ADVANCED WAVETABLE SYNTH

## KEYBOARD USER MANUAL

Version 1.8 August, 2024





Tested To Comply  
With FCC Standards  
FOR OFFICE USE



This device complies with Part 15 of the FCC Rules. Operation is subject to the following two conditions: (1) This device may not cause harmful interference and (2) this device must accept any interference received, including interference that may cause undesired operation.

This Class B digital apparatus meets all requirements of the Canadian Interference-Causing Equipment Regulations.

Cet appareil numérique de la classe B respecte toutes les exigences du Règlement sur le matériel brouilleur du Canada.

For Technical Support: [support@groovesynthesis.com](mailto:support@groovesynthesis.com)

### **CALIFORNIA PROP 65 WARNING**

This product may expose you to chemicals including BPA, which is known to the State of California to cause cancer and birth defects or other reproductive harm. Though independent laboratory testing has certified that our products are several orders of magnitude below safe limits, it is our responsibility to alert you to this fact and direct you to: <https://www.p65warnings.ca.gov> for more information.

# Table of Contents

<b>A WORD FROM THE GROOVE DUDES</b> .....	viii
<b>Getting Started.</b> .....	1
Sound Banks .....	1
<b>What Is a Wavetable?</b> .....	2
<b>Main Display.</b> .....	3
<b>Selecting Programs.</b> .....	4
<b>Editing Programs.</b> .....	4
Comparing an Edited Program to its Original State .....	4
<b>Creating a Program from Scratch</b> .....	5
<b>Saving a Program</b> .....	6
Canceling Save. ....	6
<b>Naming a Program.</b> .....	7
<b>Creating “Favorites” Lists</b> .....	7
<b>Working with Multi-Parts</b> .....	9
<b>Creating Splits</b> .....	15
<b>Connections.</b> .....	17
<b>Main Display.</b> .....	19

- Oscillators . . . . .20**
  - Oscillator Controls . . . . . 22
  - Free-Running Oscillators . . . . . 23
  - About Oscillator Levels . . . . . 24
  - Additional Controls . . . . . 24
  - About Wave Flow . . . . . 27
  
- Wave Envelope . . . . .28**
  - Editing a Wave Envelope . . . . . 29
  - Wave Envelope Menu Parameters . . . . . 31
  
- 3rd Wave OS 1.8 Sampling . . . . .32**
  
- Adding Samples to the 3rd Wave. . . . .33**
  - Sampling Directly into the 3rd Wave. . . . . 33
  - Importing Samples from a Computer as .wav Files . . . . . 35
  
- Saving and Assigning Samples to a Slot . . . . .36**
  - Bulk Loading .wav Files into Sample Memory . . . . . 37
  - Adding Additional Samples to a Slot to Create a Multi-Sample . . . . 41
  - Using Samples in a Preset . . . . . 42
  
- Editing Samples. . . . .42**
  - Backing Up and Restoring Samples and Sample Slots . . . . . 48
  
- Low Frequency Oscillators. . . . .50**
  - LFO Controls . . . . . 50
  - Longer LFO Frequency Values in Sync Mode . . . . . 52
  
- Filters . . . . .53**
  - Low-Pass Filter Controls. . . . . 54
  - State-Variable Filter Controls . . . . . 55
  
- Filter Envelope. . . . .57**
  - Filter Envelope Controls . . . . . 58
  
- Amplifier Envelope . . . . .59**
  - Amplifier Envelope Controls . . . . . 60

- Envelopes 3/4. . . . .62**
  - Envelope 3/4 Controls . . . . . 62
  
- Modulation . . . . .63**
  - Modulation Controls (in Display) . . . . . 64
  - Modulation Examples . . . . . 64
  
- Effects. . . . .66**
  - Effects . . . . . 66
  - Effects Limitations in Multi-Part Programs . . . . . 67
  - Effects Controls . . . . . 68
  - Effects Parameters . . . . . 69
  
- Arpeggiator . . . . .70**
  - Arpeggiator Controls. . . . . 70
  
- Sequencer . . . . .72**
  - Creating a Pattern. . . . . 73
  - Creating a Song . . . . . 74
  - Sequencing Parameter Changes . . . . . 75
  - Copying a Pattern . . . . . 76
  - Creating and Playing Independent Sequences for Each Multi-Part . 77
  
- Pan Spread. . . . .78**
  
- The Wave Surfer . . . . .79**
  - About Wave Flow and Upper Wavetables . . . . . 81
  
- Creating Custom Wavetables. . . . .82**
  - Some Technical Details About the Wave Maker . . . . . 83
  - Creating a Wavetable via the Audio In Jack . . . . . 84
  - Creating a Wavetable via USB . . . . . 86
  
- Importing Wavetables into the “P” Set . . . . .88**
  
- Importing Serum™ Wavetables . . . . .91**
  
- Miscellaneous Settings. . . . .92**

<b>Unison</b> .....	<b>.94</b>
Unison Parameters .....	95
Using Chord Memory .....	96
Polyphonic Unison Mode .....	97
<b>MIDI Program Change Messages</b> .....	<b>.99</b>
<b>MPE Support</b> .....	<b>.99</b>
<b>Global Settings</b> .....	<b>.101</b>
Global Menu Parameters .....	101
<b>How to Sound Like a Vintage PPG</b> .....	<b>.108</b>
<b>Troubleshooting the 3rd Wave</b> .....	<b>.113</b>
Contacting Technical Support .....	114
Warranty and Repairs .....	114
Calibrating the 3rd Wave .....	115
Calibrating the Filters .....	115
Checking Your Operating System Version .....	115
Exporting Programs .....	117
Importing Programs .....	118

## **A WORD FROM THE GROOVE DUDES**

Hello and thanks for purchasing the 3rd Wave!

We're a small group of synth geeks that got our start making synthesizers and music hardware and software for other companies. We created the 3rd Wave out of a love for classic wavetable synths of the past and a desire to develop a worthy successor of our own.

We hope you love it. We sure do. To use a favorite phrase of ours, we think it's "Rippin' Action."

Your support means everything to us.

*The Groove Synthesis Gang*

Contact us at:  
[support@groovesynthesis.com](mailto:support@groovesynthesis.com)



# Getting Started

The 3rd Wave is a 24-voice wavetable synthesizer with analog filters, versatile modulation, and advanced wave playback capabilities. The secret to its power lies in its numerous 64-position wavetables (both classic and new) and its 6-stage Wave Envelope, which allows you to sweep through these wavetables in variety of ways. Since each of the 3rd Wave's three oscillators can generate a different wavetable with a different wave envelope, the sonic possibilities are immense.

The good news is that this power is easy to access. The majority of the 3rd Wave's essential sound-shaping controls are within easy reach on its front panel.

So dive right in and start checking out presets. Don't hesitate to turn knobs and press buttons to get a feel for how things sound and how the controls work. When you have time, read this manual to learn essential tasks such as how to use the wave envelopes, how to save presets, and how to use the multi-part controls.

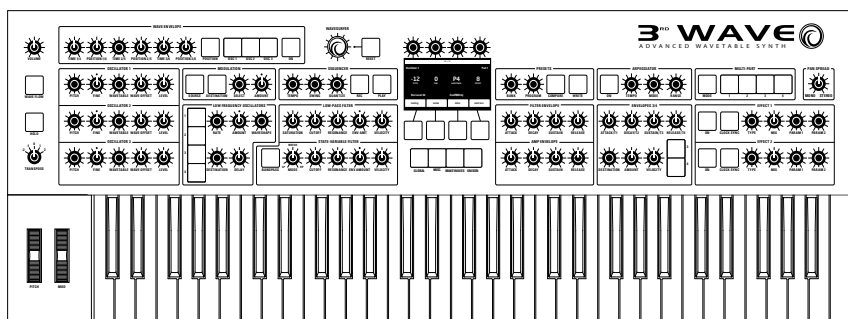

3rd Wave front panel

## Sound Banks

The 3rd Wave has 500 presets divided into 5 banks of 100 presets. You can edit and resave any of these sounds. Each preset has interesting things mapped to the Mod Wheel of your MIDI controller. Some presets also contain a sequence. Since the synth is 4-part multitimbral, many presets have additional sounds programmed into each of its 4 parts. This gives you a vast library of sounds to layer or copy.

# What Is a Wavetable?

A wavetable is a collection of single-cycle waveforms. The 3rd Wave's wavetables have 64 waveforms arranged in a sequence that often harmonically relates one waveform to the next so that as you move from one waveform to another, the sound evolves smoothly. When enabled, the `WAVE FLOW` control enhances this smoothing effect. With `WAVE FLOW` off, the waveforms are not smoothed as they step from one to the next. This stepping is more obvious in some wavetables than in others.

You can sweep forward or backward through the waveforms in a wavetable using the various controls on the 3rd Wave. You can also choose to play just a single waveform within a wavetable without sweeping by turning off the Wave Envelope (which is the default way to control wave sweeping). With the Wave Envelope off, whatever waveshape you choose within a wavetable using the `WAVE OFFSET` knob is the static wave that you will hear (as long as no other mod sources are sweeping through the wavetable).

The image below shows the wavetable window, which is available on each of the 3 oscillators.

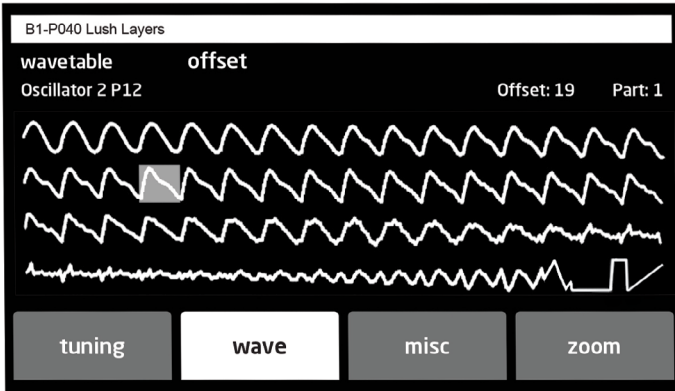

The 64 waves in wavetable P12 with waveshape 19 selected

# Main Display

The front panel of the 3rd Wave has its most frequently used controls. There are additional controls (as well as numeric display of values) visible in its main display.

For example, adjusting a knob or switch in the Oscillator section reveals the Oscillator parameters in the display. The display also reveals additional parameters not found on the front panel. You can select and edit these additional parameters using the four soft buttons and soft knobs located above and below the display.

The soft knobs are detented encoders that are useful for dialing in values with precision. The soft buttons select between various menu tabs.

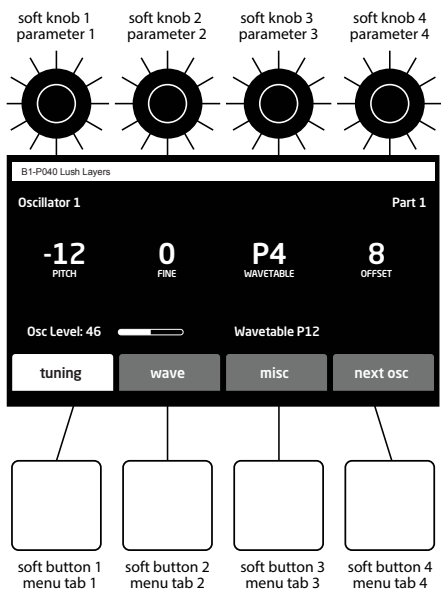

The Main display

# Selecting Programs

Use the **BANK** and **PROGRAM** knobs to select and recall programs.

## *To choose a program:*

1. Turn the **BANK** knob to select the bank you want.
2. Turn the **PROGRAM** knob to select a program within that bank.

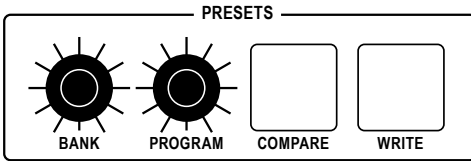

Presets section

# Editing Programs

Because the majority of the sound-shaping controls of the 3rd Wave appear on its front panel, editing an existing program is simple: just turn a knob and listen to its effect. Keep turning knobs and pressing buttons. If you like what you've created, save the program. (See "Saving a Program" on page 6.)

## Comparing an Edited Program to its Original State

When editing a program, you can compare its edited state to its original state to evaluate your edits.

### *To compare an edited program to a saved version:*

1. Edit a program.
2. Press the **COMPARE** button. It lights up, indicating Compare mode.
3. Play the keyboard to hear the saved version of the sound.
4. To disable the compare function and return to the edited sound, press the **COMPARE** button again to turn it off. Programs can't be written while in Compare mode.

It's useful to be able to check the value of a parameter for reference. Normally, to make a parameter value appear in the display, you have to turn the parameter's knob, which will change the parameter value. But there is a way to do this without changing the value:

***To check the value of a parameter without changing it:***

1. Press and hold the COMPARE button.
2. Turn any parameter knob. The value appears in the display.
3. To return to normal operation, release the COMPARE button.

## **Creating a Program from Scratch**

An existing program can be very useful as a jumping off point for new sounds. But it's also useful (and educational) to create a new sound from scratch. The 3rd Wave makes this easy by providing a "basic preset" that you can quickly recall at any time. This preset is simple, with three "P" waves as its basis, a simple wave envelope, and filter and amplifier envelopes set to useful values.

Mod and pitch wheels are set to useful values as well, with a mod wheel routed to wave offset to sweep through the waveforms within the wavetables.

***To recall the basic preset:***

1. Use the BANK and PROGRAM knobs to choose any preset.
2. Press soft button 1 (INIT PROG). This resets the current sound to the basic preset.

# Saving a Program

If you've created a sound that you like, you'll probably want to save it. Saving a program overwrites a previously saved program.

## **To save a program to the same preset location:**

1. Press the `WRITE` button. It begins blinking.
2. Press the `WRITE` button again or press soft button 4 (`OK`). The program is saved.

## **To save a program to a different location:**

1. Press the `WRITE` button. It begins blinking.
2. Turn soft knob 1 to select a different bank. Turn soft knob 2 to select a different program location.
3. Press the `WRITE` button again or press soft button 4. The program is saved.



Saving a program saves any edits to programs on multi-parts 1-4.

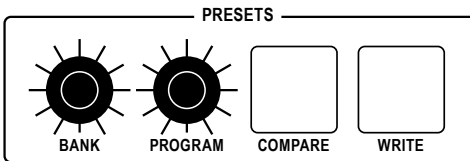

Presets section

## Canceling Save

Sometimes you may want to cancel saving a program before you commit.

### **To cancel saving:**

- If the `WRITE` button is flashing, turn any parameter knob or press any parameter button. The `WRITE` LED stops flashing and saving is canceled. You can return to editing.

# Naming a Program

You can rename a program when the WRITE command is active.

## *To rename a program:*

1. Press the WRITE button. Its LED begins blinking.
2. Turn soft knob 3 to move the cursor forward or backward.
3. Turn soft knob 4 to select a character.
4. When you're done naming the program, press the WRITE button again. The program is saved.

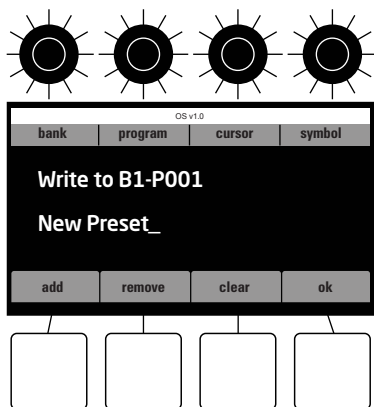

Naming a program

## Creating “Favorites” Lists

The 3rd Wave provides 500 factory presets in 5 banks of 100 sounds. Scrolling through these to locate a favorite can be time consuming. To make this easier, the 3rd Wave allows you to designate presets as favorites and create up to 10 sets of these with up to 50 presets each. You can then access these sounds by pressing the FAVS command (soft button 4) in the main screen.

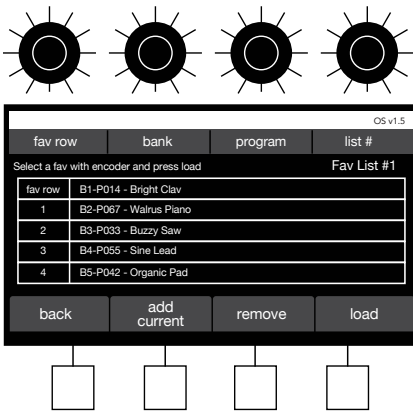

## Favorites List

### **To create a favorites list:**

1. Use the **BANK** and **PROGRAM** knobs to locate a preset that you want to designate as a favorite.
2. Press soft button 4 (**FAVS**). By default, Favorites List #1 appears. If you want to add the current preset to a different Favorites List, use soft knob 4 (**LIST #**) to select a different list.
3. In the Favorites screen, use soft knob 1 (**FAV ROW**) to scroll to the desired position (1-10) in the list.
4. Press soft button 2 (**ADD CURRENT**) to add the currently active preset to the favorites list.

### **To add additional favorites:**

1. In the Favorites screen, use soft knob 1 (**FAV ROW**) to scroll to the desired position (1-10) in the list.
2. Use soft knob 1 and soft knob 2 (**BANK** and **PROGRAM**) to locate another preset that you want to add to the current Favorites List.
3. Repeat as necessary.



### **To load a preset from the Favorites List:**

1. Turn the BANK OF PROGRAM knob to display the main Presets screen.
2. Press soft button 4 (FAVS). By default, Favorites List #1 appears. If you want to display a different Favorites List, use soft knob 4 (LIST #) to select a different list.
3. In the Favorites screen, use soft knob 1 (FAV ROW) to scroll to the desired preset in the list.
4. Press soft button 4 (LOAD). to load the selected Favorite.

## **Working with Multi-Parts**

The 3rd Wave is 4-part multitimbral, meaning that it can produce four different sounds/programs at the same time. You can layer different sounds together or assign different sounds to different keyboard zones.

When a Multi-Part button is lit, that part is active (and audible). Each part can have 2 different effects and each part can have its own sequence “track” for each pattern in the sequencer. This allows for some very powerful combinations of sounds. Saving a preset saves all multi-parts, miscellaneous settings, and sequences with the preset.

Because the 3rd Wave has 24 voices of polyphony, multi-parts equally divide the 24 voices by the number of parts active:

- If 1 part is active, that part has 24 voices.
- If 2 parts are active each part has 12 voices.
- If 3 parts are active, each part has 8 voices.
- If 4 parts are active, each part has 6 voices.



The exception to this voice allocation rule is when you are using Splits or the Sequencer. Both dynamically allocate available voices as needed. For example, if you have a four part program with sequences on each part, and 8 notes are being used by part 1, all 8 voices will play as long as the other three parts of the sequence aren't using more than 16 voices.

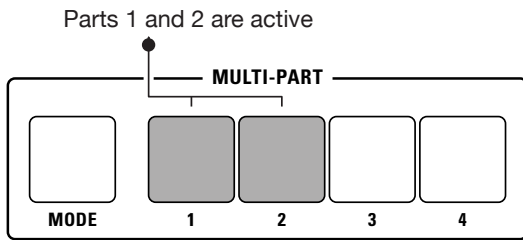

Multi-Part buttons

## Creating a Multi-Part Program

When you select a program, one or more parts will be active and the button(s) corresponding to these active parts will be lit. At least one part will also be blinking. The blinking part indicates which part you are editing when you turn a knob or adjust a parameter. You can edit more than one part at a time by selecting multiple parts simultaneously for editing. Any edits will be applied to all selected parts.

- If a Multi-Part button is lit, that corresponding part is active and audible in the current program.
- If a Multi-Part button is not lit, that corresponding part is not active and not audible in the current program.
- If a Multi-Part button is lit and blinking, that part is active, audible, and selected for editing.
- If a Multi-Part button is lit but not blinking, that part is active and audible, but not selected for editing.



When more than one part is selected for editing, you can hold down one of the buttons until it stops blinking to change which part is displayed on the screen. In addition, when you hold down the `MODE` button to select multiple parts for editing, the last button that you release will designate the part that is displayed on the screen.

### **To toggle an unlit (inactive) multi-part on:**

- Press any unlit Multi-Part button. It becomes lit and flashes, indicating that is active, audible, and selected for editing.

### **To toggle a lit (active) multi-part off:**

- Press any lit Multi-Part button. It becomes unlit and is no longer active or audible in the current program.

### **To change which active parts you are editing:**

- Hold down the MODE button and and press any Part button that is solidly lit to turn editing on for the part. The button will begin to blink indicating that you are editing the corresponding part.
- Hold down the MODE button and and press any Part button that is blinking to turn editing off for the part. The button will stop blinking, indicating that you are no longer editing the corresponding part.
- An alternative way to change which parts are being edited is to simultaneously double press the active Part buttons you would like to edit. After doing so, only the buttons you double pressed will be blinking, indicating what you are editing.

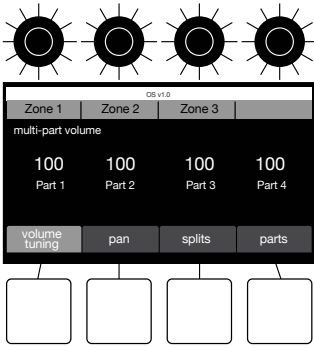

Parts 1,2,3 are active, and if flashing, will be edited simultaneously

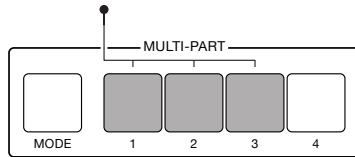

Editing multi-parts

### **To adjust the volume level of each program in a multi-part:**

1. Press the MODE button. In the display, the multi-part VOLUME/TUNING parameter is selected by default (soft button 1).
2. Use soft knobs 1-4 to adjust the volume for the individual parts.

### **To adjust the tuning of each program in a multi-part:**

1. Press the MODE button. In the display, the multi-part VOLUME/TUNING parameter is selected by default (soft button 1).
2. Press soft button 1. This toggles the controls in the display to multi-part tuning.

3. Use soft knobs 1-4 to adjust the tuning -50 to +50 cents for the individual parts.
4. To toggle back to volume controls, press soft button 1 again.

### ***To adjust the panning of each program in a multi-part:***

1. Press the **MODE** button.
2. Press soft button 2 (**PAN**).
3. Use soft knobs 1-4 to adjust the volume for the individual parts. A value of 0 (zero) is centered in the stereo field. A value of -50 is panned fully left. A value of +50 is panned fully right.



If Panning is set to 0 in the multi-part Panning menu, the front-panel **PAN SPREAD** knob controls program panning instead of this the multi-part Panning menu. In other words, if panning is set to 0 in the Mutlti-part menu, the **PAN SPREAD** knob determines the panning for odd and even voices in a program. If the **PAN SPREAD** knob is fully clockwise, each new voice played is hard-panned fully left or fully right. If the **PAN SPREAD** knob is fully counter clockwise, all voices are centered in the stereo field. A setting in between these two extremes results in a smaller amount of left to right panning as new voices/notes are played.

### ***To copy programs between parts:***

1. Press the **MODE** button. The multi-part parameters appear in the display.
2. Press soft button 4 (**PARTS**).
3. Use soft knobs 1-2 to select the **BANK** and **PROGRAM** that you want to copy from.
4. Use soft knob 3 to choose which part (1-4) you want to copy in the selected program.
5. Use soft knob 4 to select the Part in the currently active program that you want to copy the selected program/part to.
6. Once you've chosen the source program/part and which multi-part you want to copy it to in the current program, press soft button 4 (**COPY**).

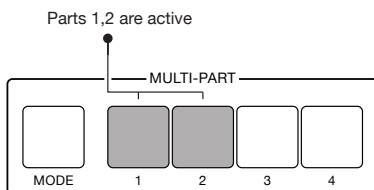
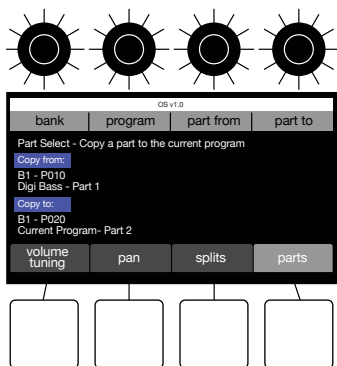

### Copying multi-parts

You can create huge-sounding stereo versions of a program by copying the same program to Parts 1 and 2, then panning part 1 hard left and part 2 hard right. To further widen the effect, vary the parameters slightly between the two parts. You can vary the envelope times, filter cutoff, tuning, or other parameters to create slight differences between the two parts.

#### **To make a stereo program:**

1. To create a stereo program, you will copy the same program to Part 1 and Part 2 and pan each Part fully right and fully left respectively.
2. Use the Bank and Program knobs to select a program that you want to make stereo.
3. Activate Parts 1 and 2 by pressing Part 1 or Part 2 button if they are not lit or blinking.
4. Press the **MODE** button. The multi-part parameters should appear in the display.
5. Press soft button 4 (**PARTS**).
6. Use soft knobs 1-2 to select the **BANK** and **PROGRAM** that you want to copy from.
7. Use soft knob 3 to choose which part (1-4) you want to copy in the selected program.
8. Use soft knob 4 to select the Part in the currently active program that you want to copy the selected program/part to. In this case, select “Current Program - Part 1” as the destination.

9. Press soft button 4 (COPY).
10. Repeat steps 3-6 but this time, in Step 5, choose “Current Program - Part 2” as the destination. This duplicates Part 1 onto Part 2 in the current program.
11. Press the MODE button to return to the main multi-part menu page.
12. Press soft button 2 (pan). Use soft knob 1 to set the panning of Part 1 to -50.
13. Use soft knob 2 to set the panning of Part 2 to +50.
14. Turn the front-panel PAN SPREAD knob fully counter-clockwise to MONO. (This forces the voices to have the same panning instead of ping-pong per voice.)
15. Play a chord on the keyboard. You will hear a true stereo version of the program.
16. To increase the stereo presence of the program, edit Part 1 or Part 2 filter cutoff, wave position, envelopes or other settings so that the two Parts are not completely identical.

***To assign multi-parts to individual rear-panel outputs:***

1. Press the MISC button under the main display.
2. If it's not already selected, use soft knob 1 to select OUTPUT ROUTING from the menu.
3. Turn soft knob 2 (GO) to navigate to the OUTPUT ROUTING page.
4. By default, MAIN is selected in the OUTPUT ROUTING page. This is the main pair of stereo outputs.
5. Use the Multi-Part buttons to select any multi-parts that you want to route to the selected rear-panel output. By default all buttons are active, so press the Multi-Part buttons to select/deselect the parts that you want to route.
6. Use soft knob 1 to select the next rear-panel output that you want to route a multi-part to.
7. As before, use the Multi-Part buttons to toggle on/off any multi-parts that you want to route to the selected rear-panel output. By default all buttons are active, so press the Multi-Part buttons to select/deselect the parts that you want to route.
8. When you have finished, press the WRITE button twice to save the multi-part routing to the program.

# Creating Splits

In addition to layering sounds, you can assign different sounds to different sections of the keyboard. This allows you to play a bass sound on the lower section of the keyboard, a pad in the middle section, and a lead in the upper section, for example.

The example below explains how to create a three-part split.

## ***To create a split program:***

1. Using what you learned in “Working with Multi-Parts” on page 9, create a program with different sounds on Part 1, Part 2, and Part 3 (bass, pad, and lead, for example).
2. Before you save the program, activate Part 1 and de-activate Part 2 and Part 3. Then save the program.
3. In the multi-part section, press the **MODE** button. The multi-part menu appears.
4. Press soft button 3 (**SPLITS**). The Splits controls appear. Part 1 is automatically assigned to Split zone 1 (if Multi-Part button 1 is active/lit). (The Split function assigns all currently active parts to whatever Split part is selected.)
5. Press soft button 3 (**ADD**). Multi-part 2 is automatically assigned to Split zone 2.
6. Press soft button 3 again (**ADD**). Multi-part 3 is automatically assigned to Split zone 3.
7. To set the keyboard range for Split 1, use soft knob 1 to scroll to Split 2. Then hold down soft button 2 (split zone) and press a key on the 3rd Wave’s keyboard to set the end of Split point 1/the beginning of Split point 2.
8. Save the program when you have finished.

### **To assign more than one Part to a Split zone:**

1. As before, create a program with different sounds on Part 1, Part 2, and Part 3.
2. Before you save the program, activate Part 1 and de-activate Part 2 and Part 3. Then save the program.
3. In the multi-part section, press the **MODE** button. The multi-part menu appears.
4. Press soft button 3 (**SPLITS**). The Splits controls appear. Part 1 is automatically assigned to Split zone 1 (if Multi-part Button 1 is active/lit).
5. To add additional Parts to Split zone 1, simply press the Multi-Part button of that part. The Split function assigns all currently active parts to the currently selected split zone.
6. To add more Split zones, press soft button 3 (**ADD**). Any multi-parts that are currently active are automatically assigned to Split zone 2.
7. If you want to remove or add a different Part to a specific Split zone, use soft knob 1 to scroll to the desired Split zone then activate only the desired Parts.
8. Save the program when you have finished.



With voice sharing off (set this with soft knob 4 in the **SPLITS** menu) you will not be able to add a part if it is already used in a different split zone. The state of the controls correspond to whichever split zone is selected in the **SPLITS** menu. In other words, you can only edit the parts associated with a single split zone at one time.



# Connections

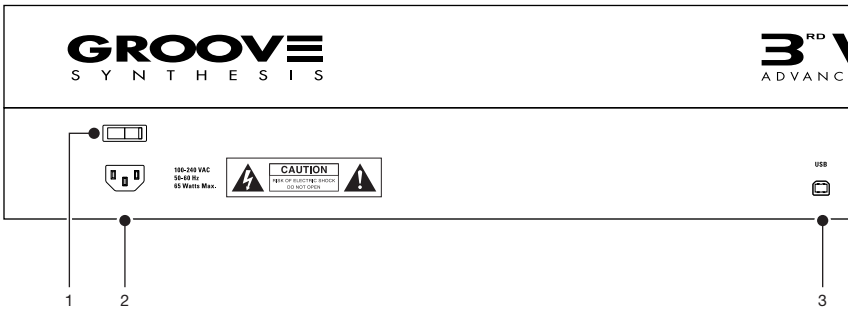

**1. POWER ON/OFF** — Turns the 3rd Wave on and off.

**2. AC POWER CONNECTOR** — Accepts a standard, grounded IEC power cord. Operates over a range of 100 to 240 volts and 50 to 60 Hz.

**3. USB** — For bidirectional MIDI communication with a computer. The 3rd Wave is a Class Compliant USB device. It doesn't require drivers when used with Mac OS or Windows.

**4. MIDI IN, OUT, and THRU** — Standard 5-pin MIDI DIN connectors.

**5. SUSTAIN** — Accepts a footswitch to control sustain. Use the Global menu's SUSTAIN FOOTSWITCH control to choose the correct behavior for your model of footswitch (PRESSED OPEN OR PRESSED CLOSED).

**6. VOLUME** — Accepts a standard expression pedal that has a variable resistor on a TRS (tip-ring-sleeve) ¼-inch phone plug. Once connected, you can use the modulation matrix to route the pedal to control a variety of things such as volume or filter cutoff frequency to add expressiveness to live performance. Use the Global menu's VOLUME PEDAL POLARITY control to choose the correct polarity for your model of footswitch (POSITIVE OR NEGATIVE).

**7. PEDAL/CV** — Accepts a second standard expression pedal that has a variable resistor on a TRS (tip-ring-sleeve) ¼-inch phone plug. Once connected, you can use the modulation matrix to route the pedal to control a variety of things.

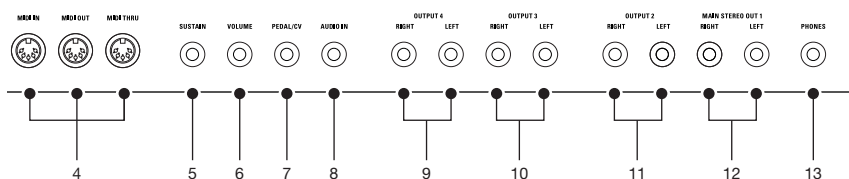

**8. AUDIO IN** — Accepts an unbalanced, 1/4-inch audio input. Connect an audio cable to this jack to create a custom wavetables with the **WAVE MAKER** utility. See “Creating Custom Wavetables” on page 82 for more details.

**9. OUTPUTS 4** — Unbalanced, 1/4-inch audio outputs. Connect audio cables to these jacks if you want separate stereo outputs for Layer 4. If no cables are connected, Layer 4 is output on the Main A Outputs.

**10. OUTPUTS 3** — Unbalanced, 1/4-inch audio outputs. Connect audio cables to these jacks if you want separate stereo outputs for Layer 3. If no cables are connected, Layer 3 is output on the Main A Outputs.

**11. OUTPUTS 2** — Unbalanced, 1/4-inch audio outputs. Connect audio cables to these jacks if you want separate stereo outputs for Layer 2. If no cables are connected, Layer 2 is output on the Main A Outputs.

**12. MAIN STEREO OUTPUTS** — Unbalanced, 1/4-inch audio outputs. These are the main stereo outputs for the synth. They carry all layers, 1-4, if no cables are connected to the other output jacks.

**13. HEADPHONES** — A 1/4-inch stereo headphone jack. Headphone volume is controlled by the **VOLUME** knob on the front panel.

# Main Display

The most frequently used controls on the 3rd Wave are on its front panel. But there are additional controls (as well as numeric display of values) visible in its main display.

For example, adjusting a knob or switch in the Oscillator section reveals the Oscillator parameters in the display. The display also reveals additional parameters not found on the front panel. You can select and edit these additional parameters using the four soft knobs and soft buttons located above and below the display.

The soft knobs are detented encoders that are useful for dialing in values with precision. The soft buttons select between various menu tabs.

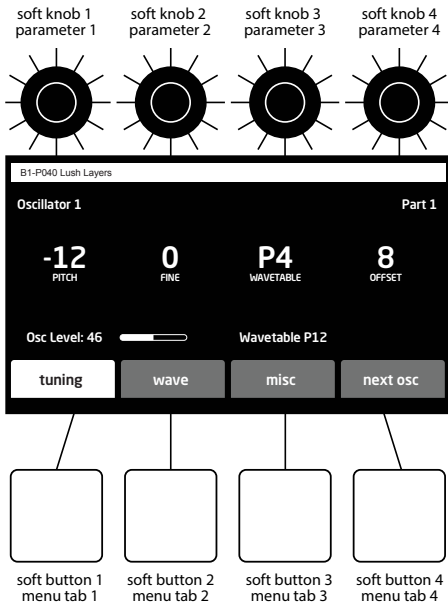

The Main display

# Oscillators

The 3rd Wave has three digital oscillators per voice. The oscillators generate the raw, unprocessed sound of the synth. All other controls on the synth modify or process the sound the oscillators make.

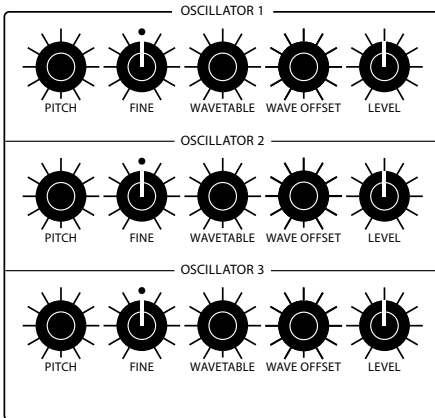

## The Oscillators

The 3rd Wave's oscillators generate four types of waveforms:

- Classic PPG-legacy waves (P00-P33)
- 3rd Wave custom waves (U00-U47)
- Analog-modeled waves (A00-A06)
- Sample playback (S00-S64)

## PPG Legacy Waves (“P” Waves)

There are 36 of these 64-waveshape wavetables. They include the original set of 8-bit wavetables from the PPG 2.2 and 2.3 as well as two sets of Prophet VS wavetables (wavetables 34 and 35). Use them to create classic wavetable sounds like those heard on recordings from the 1980s and beyond.

## Custom User Waves (“U” Waves)

There are 48 of these 64-waveshape, harmonically-complex wavetables. They differ from the “P” wave set in that they are high-resolution (96 kHz) and anti-aliased for greater fidelity and no audio artifacts at higher frequencies. In addition to these 48 wavetables, the built-in Wave Maker utility allows you to create your own custom user waves. There are 16 blank slots for custom waves. These will fill slots U48 - U64. In addition, if you want, you can overwrite any of the 48 factory user waves — though this will impact any presets that use them.

## Analog-Modeled Waves (“A” Waves)

There are 7 of these high-fidelity, high-resolution analog modeled waveforms. They are useful for creating classic subtractive synthesis sounds and effects. Modeled waveforms include sawtooth, square/pulse, triangle, sine, supersaw, and two varieties of continuously variable noise: red-pink-white and white-blue-violet. The WAVE OFFSET knob controls pulse width, supersaw detuning, and noise color, depending on which waveform is selected. Although the wave envelope doesn’t affect these analog-modeled waveshapes, you can use other modulation sources such as the LFOs or Envelopes 3/4 to modulate analog waveshapes by choosing WAVE OFFSET as a modulation destination.

## Samples (“S” Multi-Sample Slots)

As of OS version 1.8, the 3rd Wave has a sample oscillator type — the “S” type — which plays samples you can record or import into the synthesizer. The “S” oscillator type is a container for multi-samples and their individual settings.

There can be up to 8 samples in a single S sample slot, and you have up to 35 seconds of sample memory to work with. The samples can be 8 bit, 12 bit, or 16 bit with sample rates from 48 kHz down to 10 kHz. Each sample has control of keyboard placement, tuning, level, looping, cross fade type, crossfade length, and crossfade location. Any or up to all three oscillators can play samples that sound modern or as original to samplers from the past as you would like.

## Oscillator Controls

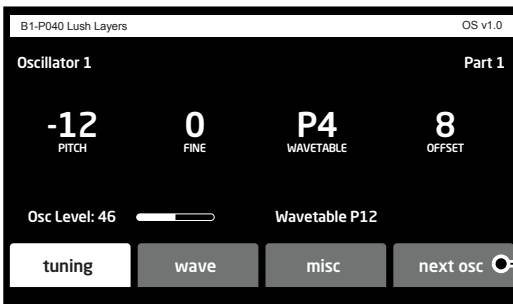

Press Soft Button 4 to switch between oscillators 1-3

**PITCH:** (C0-C8) Sets the base frequency of the oscillator. Pitch range is from C0 to C8. You can also transpose the pitch of the keyboard up or down two octaves with the TRANSPOSE knob.

**FINE:** (-50 to +50) Adjusts tuning up or down in small increments. Steps are in cents (50 cents = 1/2 semitone). The 12 o'clock position is centered (no detuning).

**WAVETABLE:** (various within the P, U, A and S wave sets) Selects one of the many wavetables on the 3rd Wave. Each wavetable in the “P” and “U” sets is a collection of 64 individual waveforms. You can sweep through the various waveforms for a shifting, evolving texture using the Wave Envelope, or if you turn off the Wave Envelope, you can set the oscillator to a fixed waveshape within a wavetable (or one of the analog waveshapes in the “A” set of waves).

**WAVE OFFSET:** (0-63) Selects one of the 64 waves within the chosen wavetable. If you sweep through the wavetable using the Wave Envelope, the specific wave you choose using the WAVE OFFSET will act as the start point. The oscillator will then sweep through the subsequent waveforms in the wavetable.

**LEVEL:** (0-100) Sets the output level of the oscillator.

## Free-Running Oscillators

By default, the virtual analog oscillators on the 3rd Wave restart their wave cycle each time you press a key. In contrast, fully-analog voltage-controlled oscillators are “free running” and are continuously generating their waveshapes. This means that when you strike a key, the waveshape can be anywhere in its wave cycle — and not necessarily at its beginning.

This significance of this is that when a sound is generated by two or more oscillators, their respective phases will most likely not be in sync. This can create a very “organic” sound which has subtle shifts in volume.

You can emulate this behavior on the 3rd Wave by enabling the `FREE RUNNING ANALOG OSC` parameter in the `MISC` menu. Be aware that this feature only applies to the virtual analog oscillators (the “A” waves) and not the wavetables (the “P” and “U” waves).

### ***To enable free-running oscillators:***

1. Press the `MISC` button.
2. Use soft knob 1 to scroll to the `FREE RUNNING ANALOG OSC` setting.
3. Use soft knob 2 to scroll to set this parameter to `ON`.

There are two things to be aware of when using free-running virtual analog oscillators. First, as noted earlier, when two or more oscillators are running at the same time, the phase of the waveforms will not be reset and could start at any position. As a result, there will be some phase cancellation compared to having the oscillators always start at the same point. You will hear the notes change their volume level slightly as the oscillators start and drift in and out of phase with each other.

Second, in the default mode, the 3rd Wave’s virtual analog oscillators always start at zero. But in Free-Running mode, the oscillators could start at any point in their phase position. In some cases, depending on the phase position, this can cause a click at the beginning of a note. It is noticeable mostly if you are using a sine wave, and less noticeable when you are using a sawtooth or square wave. If you want to avoid a potential click, try use setting the Amp Envelope’s `ATTACK` parameter to `+20` or higher.

## About Oscillator Levels

Each oscillator has a range of 0-100 for its **LEVEL** parameter. If you are creating sounds using more than one oscillator, setting the levels of each oscillator too high could result in distortion — though this isn't always a bad thing depending on the type of sound you'd like to create. If you don't want distortion to occur, set the oscillator levels so that the sum of the three oscillator levels is no higher than 100.

The other way to cause distortion into the filters is with the **SATURATION** control in the low-pass filter. Even if the sum of your oscillator levels is less than 100, you can still distort or “saturate” the filters by turning up the **SATURATION** control. At first this will only sound like the volume is increasing, but as you increase the amount of saturation, you will create more harmonic distortion.

## Additional Controls

In addition to the front panel controls for the oscillators, there are also several parameters accessible through the soft buttons/tabs in the main display

### Tab 2 - Wave

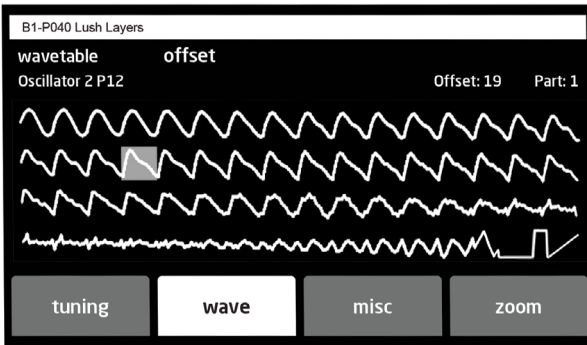

**SOFT KNOB 1:** Selects any wavetable in the P and U wave sets.

**SOFT KNOB 2:** Sets the wave offset (1-64) within the selected wavetable.



## Tab 3 - Misc

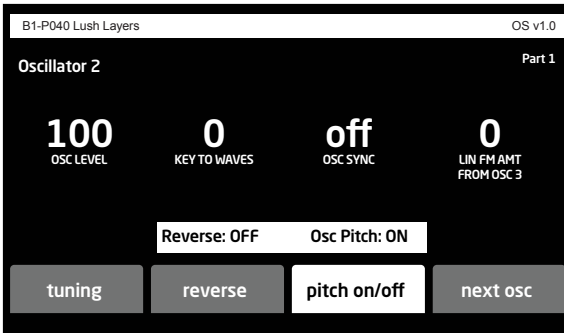

**OSC LEVEL:** (0-100) Sets the output level of the oscillator.

**KEY TO WAVES:** (0-127) Controls the Wave Offset using Note Number. In other words, as you play up or down the keyboard, the wave offset will change according to the key that you play. Higher values create a broader range of timbral change across the keyboard. Setting **REVERSE** to **ON** (by pressing soft button 2) changes the order that the wavetable is spread across the keyboard so that the highest offset is at the bottom of the keyboard and that offset 0 is at the top. This is the order that the PPG used.

**OSC SYNC:** (On. Off) Turns on oscillator hard sync. Sync forces an Oscillator to restart its cycle every time the oscillator that is synced restarts its cycle. For example, turning on Sync for Oscillator 1, syncs it to Oscillator 2. Similarly, turning on Sync for Oscillator 2, syncs it to Oscillator 3. Turning on Sync for Oscillator 3, syncs it to Oscillator 1. This creates harmonically complex waveforms, especially when the frequency of Oscillator 1 is set to a higher or lower interval (pitch) than Oscillator 2. For dramatic effects, modulate the pitch of the synced oscillator using the Envelope 3 or 4.



Oscillator Sync is not currently available on User wavetables (“U” waves).

**LIN FM AMT FROM OSC (1,2, or 3):** (0-127) Frequency modulation or *FM*, allows one oscillator (the *modulator* in FM synthesis terms) to modulate the frequency of another oscillator (the *carrier*). This creates complex harmonics called *sidebands*. The 3rd Wave features linear FM like that found in classic DX-style synths. In such synths, sine waves are used for both the carrier and modulator. Although sine waves often produce more predictable harmonic results, the 3rd Wave allows you to use any wavetable/waveshape for even more complex timbres.

The following table shows the modulator/carrier relationship between the oscillators.

Carrier	Modulator
Oscillator 1	Oscillator 2
Oscillator 2	Oscillator 3
Oscillator 3	Oscillator 1

Turning up LIN FM AMT FM for Oscillator 1 causes it to be modulated by oscillator 2, turning up FM for Oscillator 2 causes it to be modulated by Oscillator 3, and so on.

**REVERSE:** (On. Off) Set REVERSE on or off for KEY TO WAVES. See KEY TO WAVES for more information.

**PITCH ON/OFF:** (On. Off) Pressing soft button 3 in the MISC screen toggles keyboard pitch tracking on/off for the selected oscillator. When set to ON, the selected oscillator functions normally, changing its pitch according to notes you play on the keyboard. When set to OFF, the selected oscillator does not change its pitch. Instead, it stays fixed at the pitch set with the PITCH and FINE parameters.

## About Wave Flow

The `WAVE FLOW` button toggles smoothed wavetable sweeping on and off. When `WAVE FLOW` is on, the waveshapes within a wavetable morph smoothly into each other. When `WAVE FLOW` is off, waveshapes within a wavetable “step” from one to another in a more audible way. This effect is more obvious on certain wavetables than others.

### Wavetable Smoothing

Turning `WAVETABLE SMOOTHING` on applies interpolation to smooth the transitions between the individual waveforms in a selected wavetable when the Wave Envelope or other modulation source sweeps through them. This setting applies to both “P” waves and “U” waves. In both cases it is most noticeable on low notes, where you will hear a growling quality to the note as you jump between waveforms in the wavetable.

### Waveform Smoothing

Turning `WAVEFORM SMOOTHING` on applies interpolation to the waveform and pitch of individual notes for optimal pitch accuracy. In contrast, the original PPG 2.2 and 2.3 did not use interpolation, and when you played different notes on the keyboard, the PPG would use the closest sample in the small 128 sample waveform. As a result, unless you played a note that fell exactly on a sample value, it would be slightly off pitch. So, with `WAVEFORM SMOOTHING` on, note pitch is exact. With it off, notes are slightly out of tune due to the lack of interpolation, as they would be in the PPG. This is most noticeable in high notes, where the lack of accuracy results in aliasing. It is also noticeable in low notes, where the note will growl and have noticeable artifacts when changing the pitch with pitch bend or LFO pitch modulation.



Pressing the `WAVE FLOW` button also gives you access to the “Use Upper Wavetable” feature, which was unique to the PPG. Enabling this function gives you the ability to reach the last 4 waveforms in each of the P wavetables, and then to move into wavetable P30, the “upper wavetable.” This was necessary on the original PPG in cases when modulation caused wave sweeping to extend beyond the final waveshapes in a wavetable.

# Wave Envelope

The Wave Envelope is a special-purpose 6-stage envelope generator dedicated to wave sequencing. The purpose of this envelope is to step through the waveforms in a wavetable. The envelope lets you choose a time and “position” (range of travel range within the wavetable) for each of its 6 stages.

By using the Wave Envelope to cycle through the waveforms in a wavetable you can create continuously shifting timbres that evolve and move. Because you can do this for each of the 3 oscillators at once, you have an amazingly rich palette of sounds at your fingertips. Add to this the 3rd Wave’s ability to layer up to 4 different sounds at once and you can imagine the complexity of sounds you can create. This is the very heart and soul of the 3rd Wave.



To smoothly transition between waveshapes during wave cycling, turn on the Wave Flow button.

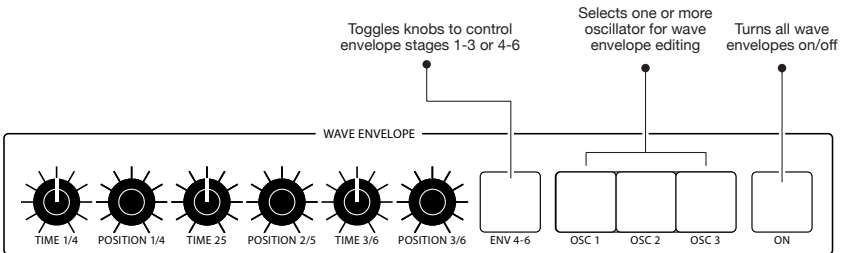

The Wave Envelope buttons

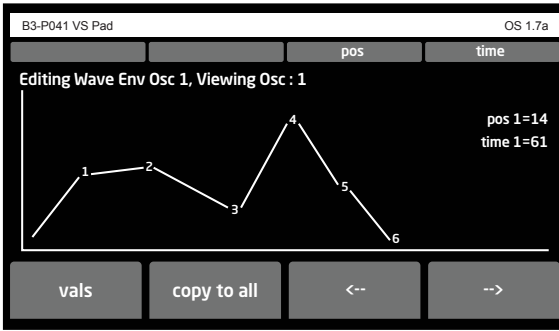

Example Wave Envelope screen

## Editing a Wave Envelope

Each of the three Wave Envelopes (one for each oscillator) has 6-stages. Each stage has a POSITION and TIME parameter.

POSITION sets which waveshape within the 64-waveshape wavetable a particular stage in the envelope reaches before moving to the next stage. In other words, it determines the range of travel from waveshape to waveshape as the envelope moves along from stage to stage.

TIME sets how quickly the oscillator sweeps through the wavetable to get to the next envelope stage/wave position.

### **To use the Wave Envelope:**

1. In the Oscillator section, turn up the level of Oscillator 1 to about 75.
2. In the Oscillator section, use the Wavetable knob to choose the wavetable that you want on Oscillator 1. Note that the wave envelope only affects “P” and “U” wavetables and not “A” wavetables.
3. On the same oscillator, use the Wave Offset knob to choose a specific waveform within that wavetable. This will be the start point for wave cycling. By default, WAVE OFFSET is set to 0 and wavetable playback begins at wave position 1.
4. In the Wave Envelope section, press the On button. This enables wave sweeping.
5. In the Wave Envelope section, press the Osc 1 button. This activates editing for Oscillator 1’s wave envelope.

- In the Wave Envelope section, make sure that the ENV 4-6 button is not enabled/lit. When unlit, envelope stages 1-3 are active for editing. But if the ENV 4-6 button is enabled/lit, envelope stages 4-6 are active for editing. At this point, we want to begin editing stages 1-3.

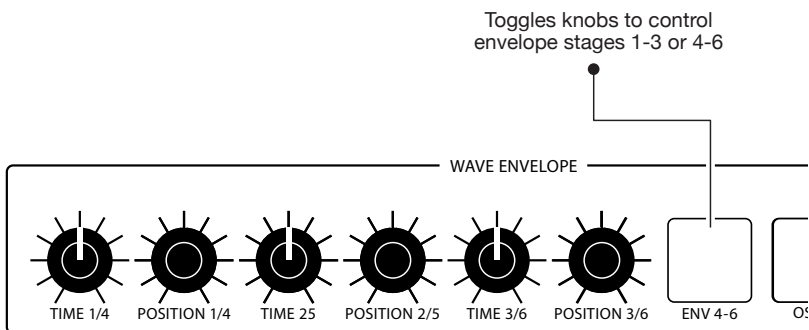

The Wave Envelope ENV 4-6 button

- Turn the Time 1/4 knob to set a length for stage 1 of the envelope. This determines how long it will take to cycle from the waveshape you chose with the Wave Offset knob through the range of waves you will set in the steps below.
- Turn the Position 1/4 knob choose a travel range within the wavetable. The higher the setting, the broader the range of the sweep within the wavetable.
- Turn the Time 2/5 knob to set a length for stage 2 of the envelope. This determines how long it will take to cycle from the waveshape you chose with the Position 1/4 knob through the range of waves you will set with the Position 3/6 knob.
- Turn the Position 2/5 knob choose a travel range within the wavetable. The higher the setting, the broader the range of the sweep.
- Repeat steps 7 and 8 for the remaining stages in the Wave Envelope.
- To set the parameters for stages 4-6 in the Wave Envelope, press the ENV 4/6 button. This toggles the function of the knobs from stages 1-3 to 4-6.
- Repeat this entire process for Oscillators 2 and 3 if you like.

14. Be sure to turn up the `LEVEL` of each oscillator so that you can hear it. Additionally, in the wave envelope section, enable the `Osc 1`, `Osc 2`, or `Osc 3` button for the oscillator wave envelope that you want to edit.
15. Finally, make sure that the on button is enabled/lit so that the wave envelope is applied to the oscillators. If it is not on, the oscillator waveforms are not swept by the envelope. Instead they generate only the single-cycle waveform selected with the `WAVETABLE` and `WAVE OFFSET` controls.

## Wave Envelope Menu Parameters

**ENV GRAPH:** This toggles the display between a graphical representation of the Wave Envelope and the various controls associated with the Wave Envelope.

**COPY TO ALL:** Copies the Wave Envelope of the currently selected oscillator all oscillators.

**LOOP ON:** Enables wave envelope looping. When on, the wave envelope will repeatedly cycle through the current wavetable as long as a key is held down.

**LP START PT:** Selects the envelope stage at which wave envelope looping begins.

**RELEASE PT:** Selects the envelope stage at which wave envelope looping ends.

**LEFT ARROW:** On the graphic envelope display, pushing this soft button selects the envelope stage to the immediate left of the currently selected position. The wave position can then be edited with soft knob 3.

**RIGHT ARROW:** On the graphic envelope display, pushing this soft button selects the envelope stage to the immediate right of the currently selected position. The wave position can then be edited with soft knob 3.

# 3rd Wave OS 1.8 Sampling

As of OS version 1.8, the 3rd Wave has a new oscillator type — the “S” type — that plays samples you have recorded or imported into the synthesizer. The “S” oscillator type is essentially a container for multi-samples and their individual settings.

To use the “S” oscillator, you have to first record or import samples into the 3rd Wave. You must then assign the samples to a specific multi-sample container in order to access the multi-sample with the WAVETABLE knob, just as you would with a standard wavetable or virtual analog waveform. We refer to this container as a “slot” and that is how it appears in the various sampling-related screens on 3rd Wave.

Each multi-sample slot can contain a single sample or a collection of up to eight multi-samples spread across the keyboard. Each sample within a multi-sample slot can have its own independent loop, crossfade, key range, and tuning settings.

Use the sample oscillators alone or in combination with the 3rd Wave’s standard wavetable and virtual analog oscillators to create complex and compelling sounds.

## ***Audio requirements:***

- monophonic audio (in .wav format when imported over USB)
- sample rates: from 48 kHz to 10 kHz when imported from USB
- bit depths: 16-bit, 12-bit, 8-bit

The 3rd Wave has 3.3 MB of memory for sample data. This allows up to 35 seconds of sampling time at 48 kHz. Samples with a lower sample rate use less memory. If you want to maximize sampling time at the expense of fidelity, try using a sample rate of 24 kHz or 12 kHz. These lower sample rates produce a grungier sound similar to low-resolution vintage samplers.

In addition, after importing or recording, you can set the bit depth of a sample to 16 bit, 12 bit, or 8 bit without permanently modifying the original sample data. Lower bit-depths use the same amount of memory as higher bit depths.



# Adding Samples to the 3rd Wave

There are two ways to add samples to the 3rd Wave:

- Record directly into the AUDIO IN jack on the rear panel of the 3rd Wave
- Load a mono-format .wav file from your computer onto the 3rd Wave via USB

## Sampling Directly into the 3rd Wave

*To record a sample directly into the 3rd Wave:*

1. Connect your audio source to the AUDIO IN jack on the rear panel of the 3rd Wave.
2. Press the GLOBAL button and use soft button 1 to scroll to the MANAGE SAMPLE MEMORY setting.
3. Turn soft knob 2 to select GO.

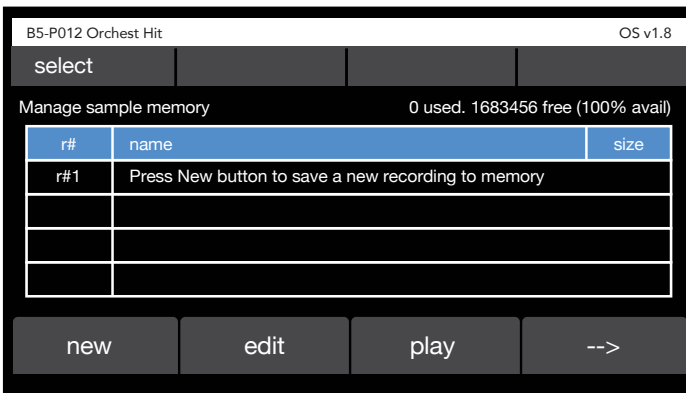

Manage Sample Memory screen

4. In the SAMPLE MEMORY SCREEN, press soft button 1 (NEW). The NEW SAMPLE RECORDING screen appears. Here you can adjust input gain and arm the 3rd Wave for recording.

5. If you want to change the input sample rate before you record your sample, press soft button 4 to go to the next screen, then press **OPTIONS**. Use soft knob 1 to select the desired sample rate (48 kHz, 24 kHz, or 12 kHz). When you have finished, press soft button 1 to return to the previous screen



Choosing a sample rate of 24 kHz or 12 kHz will reduce sample resolution (and fidelity) and consume less memory than sampling at 48 kHz.

6. Adjust the level of your audio source for optimum volume. If necessary, use soft knob 4 (**INPUT GAIN**) to increase or decrease recording level. Be careful not to clip the audio input or the sample will be distorted.
7. When you are ready, press soft button 1 (**ARM**) then play your audio source. With recording armed, the 3rd Wave will automatically start recording when it detects a signal from the audio source. It will automatically stop recording when the signal ends.
8. Press soft button 2 (**PLAY**) to hear the sample you have captured. If you want to re-record the sample, press soft button 1 (**ARM**) and repeat step 7.
9. Once the sample is captured, you can trim its length by turning soft knob 1 (**START**) to adjust the start point and soft knob 2 (**END**) to adjust the end point. The start and end points are shown on the graph with blue lines.
10. If you are happy with the sample, press soft button 3 (**SAVE**) to navigate to the **SAVE SAMPLE** screen. Refer to “Saving and Assigning Samples to a Slot” on page 36 for details on the various settings you will find there.

## Importing Samples from a Computer as .wav Files

A second way to add samples to the 3rd Wave is to load them from your computer. The files must be monophonic .wav files.



When import a .wav file, the 3rd Wave will automatically convert it to 16-bit format with the option to lower the bit depth when you assign it to a slot. It will read and import sample rates ranging from 48 kHz down to 10 kHz.

### **To import a sample from your computer as a .wav file:**

1. Connect the 3rd Wave to your computer using the USB connector on the back of the synth. Once connected, the 3rd Wave will show up on your computer desktop as an external drive called “THIRDWAVE.”
2. Open the “AUDIO” folder on the 3rd Wave. Make sure there are no existing files in the folder. If there are files in the folder, remove them before adding new ones.
3. Copy the sample from your computer into the “AUDIO” folder on the 3rd Wave.
4. Press the GLOBAL button and use soft knob 1 to scroll to the MANAGE SAMPLE MEMORY setting.
5. Turn soft knob 2 to select GO.
6. In the SAMPLE MEMORY SCREEN, press soft button 1 (NEW). The NEW SAMPLE RECORDING screen appears.
7. Press soft button 4 (right arrow) to see more options.
8. In the screen that appears, press soft button 2 (LOAD FILE). The name of the file that you copied appears in the screen. Press soft button 4 (OK) to load the file.
9. Press soft button 2 (PLAY) to hear the sample you have captured.
10. Once the sample is captured, you can trim its length by turning soft knob 1 (START) to adjust the start point and soft knob 2 (END) to adjust the end point. The start and end points are shown on the graph with blue lines.
11. If you are happy with the sample, press soft button 3 (SAVE) to navigate to the SAVE SAMPLE screen. Refer to “Saving and Assigning Samples to a Slot” on page 36 for details on the various settings you will find there.

## **Saving and Assigning Samples to a Slot**

When you assign a sample to a slot for playback you can set several options in the assigned sample, including its name, its assigned root note, its bit-depth, and more.

A key consideration is which multi-sample slot you will save the sample into. If you save it into a new, empty slot, the container will have just a single sample in it. You can also save the sample into an existing container (one that already contains at least one raw sample) you will create a multi-sample. Any multi-sample slot can contain up to eight different samples.

### ***To assign a sample to a slot:***

1. In the *SAVE SAMPLE* screen, use soft knob 1 to select the sample memory slot. By default, this will be set to the first empty memory container. Saving the sample to an empty container will create a new slot that only contains this one sample.
2. Alternatively, use soft knob 1 to select a container that already has at least one sample in it if you want to add to an existing slot. You can have up to 8 samples in a slot, and you can spread them across the keyboard by assigning their respective root notes (see below).
3. To assign the root note of a sample, press the corresponding key on the 3rd Wave keyboard. When you play this note, the sample will be at the same pitch it was recorded. Each assigned sample in a slot has up to a two-octave range above or below the assigned note. The range depends on where other samples in the same slot have been assigned and also what you enter as the upper and lower range for this particular sample.
4. Use soft knob 2 to set the bit depth to either 16 bit, 12 bit, or 8 bit, depending on your preference. Lower bit depths reduce fidelity but use the same amount of memory as higher bit depths
5. Use soft knob 3 and soft knob 4 to name the sample.
6. When you have finished, press soft button 4 (OK) to assign it to your selected slot and to save it to internal memory.

After you assign a sample to a slot, the `SAMPLE EDITING` screen appears. (See “Save Sample screen” on page 37.) Here you can loop the sample, adjust its start and end point, and more. See “Editing Samples” on page 42 for more information.

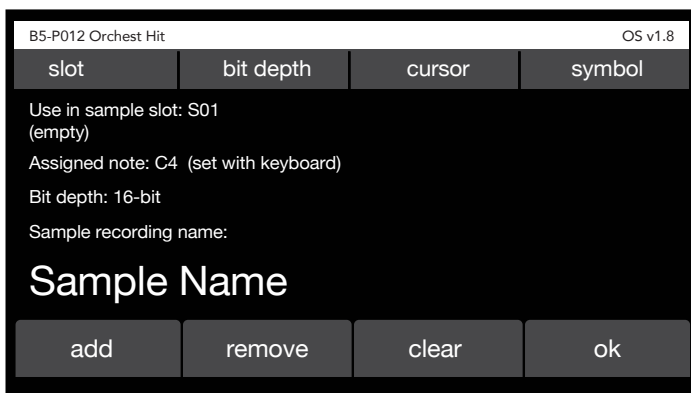

Save Sample screen



Once a sample is assigned to a slot, you can access it with the `WAVETABLE` knob in the `OSCILLATOR` section of the 3rd Wave and play it. It will appear in the “S” category, which follows the virtual analog waveforms in the “A” category. Select an “S: slot with the desired sample(s) to play and use it in a program.

## Bulk Loading .wav Files into Sample Memory

You can load multiple raw .wav files from your computer into the 3rd Wave in a single pass by using the `MANAGE SAMPLE MEMORY` command in the `GLOBAL` menu. Note that there is a distinction between a raw sample and the “S” slot that a sample is assigned to for playback in an oscillator.

The 3rd Wave is only importing the raw samples into memory with the `BULK LOAD` command. It is not assigning them to a sample slot. You will need to make this assignment for each sample after you have imported them using the `MANAGE MULTISAMPLES` command.

### To bulk load .wav files to sample memory:

1. Connect your computer to the USB port on the back of the 3rd Wave using a USB cable.
2. Once connected, the 3rd Wave will show up on your computer desktop as an external drive called “THIRDWAVE.”
3. On your computer desktop, open the “AUDIO” folder on the 3rd Wave. Make sure there are no existing files in the folder. If there are files in the folder, remove them before adding new ones.
4. Copy up to 100 mono-format .wav files from your computer into the “AUDIO” folder on the 3rd Wave.
5. Press the GLOBAL button and use soft knob 1 to scroll to the MANAGE SAMPLE MEMORY setting.
6. Turn soft knob 2 to select GO.

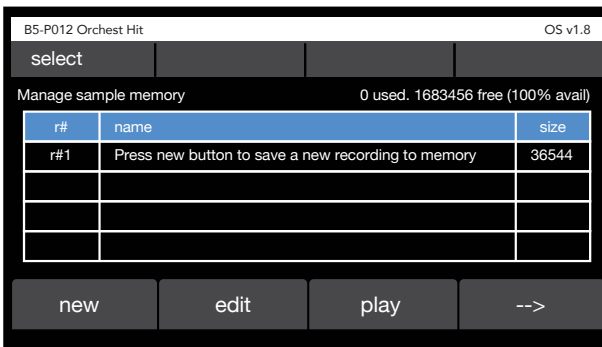

Manage Sample Memory screen (page 1)

7. Press soft button 4 (right arrow) to see more options.
8. Press soft button 2 (BULK LOAD). A screen appears indicating how many .wav files are currently in the “AUDIO” folder on the 3rd Wave.
9. Press soft button 4 (OK) to load the files.

10. After the files have been imported, the Manage Sample Memory screen appears, showing each file and its size.

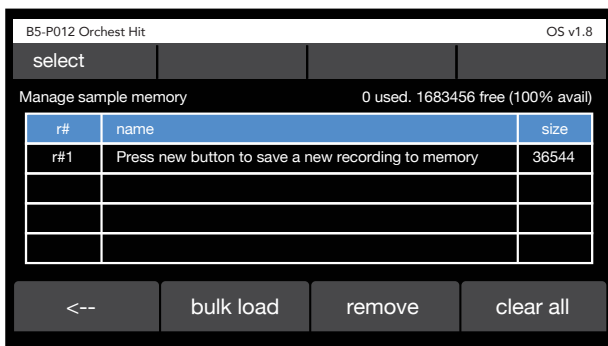

Manage Sample Memory screen (page 2)

Now that you have imported the samples, you can assign them to sample containers. They will then be available in the “S” category of any of the three oscillators and can be used in programs for playback.

**To assign existing samples from memory into sample slots:**

1. Press the GLOBAL button and use soft knob 1 to scroll to the MANAGE MULTISAMPLES setting.
2. Turn soft knob 2 to select GO. The SAMPLE EDITING screen appears as seen below.
3. Use soft knob 1 to select the desired multi-sample container.

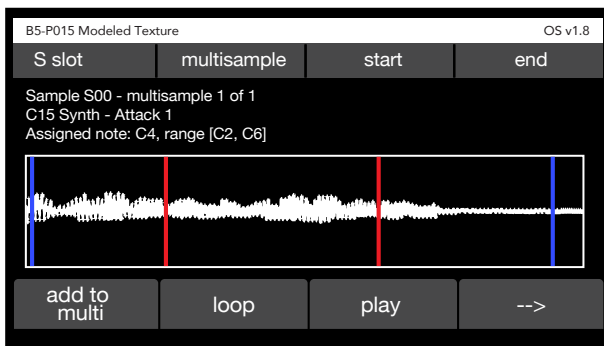

Sample Edit screen (page 1)

4. Press soft button 1 (ADD TO MULTI). A list of all samples currently in memory appears as shown below.
5. Use soft knob 1 to select the desired sample.
6. Before pressing soft button 4 (SELECT) to assign the sample to the container, set the assigned note for the sample by pressing a key on the keyboard.
7. If you are adding multiple samples to the container (8 maximum) set each of their assigned notes as you load them to map them across the keyboard.
8. Press soft button 4 (SELECT) to add the sample to the container.

B5-P012 Percussion		OS v1.8
select		
Select multisample		
Assigned note: C4 (use keyboard to set)		1034567 used. 648889 free (38% avail)
r#	name	size
r#1	Orch hit	36544
r#2	Kick	23000
r#3	Snare	25440
r#4	Tom	26789
new      back      play      select		

Multi-sample slot screen



## Adding Additional Samples to a Slot to Create a Multi-Sample

You can create a multi-sample container by adding more than one sample into the same slot. This is useful for creating drum kits, sound effects sets, or instruments that have multiple samples across the range of the keyboard.

### **Adding more than one sample into to a container:**

1. Press the GLOBAL button and use soft knob 1 to scroll to the MANAGE MULTISAMPLES setting.
2. Turn soft knob 2 to select GO.
3. In the SAMPLE EDITING screen, use soft knob 1 to select the desired sample.

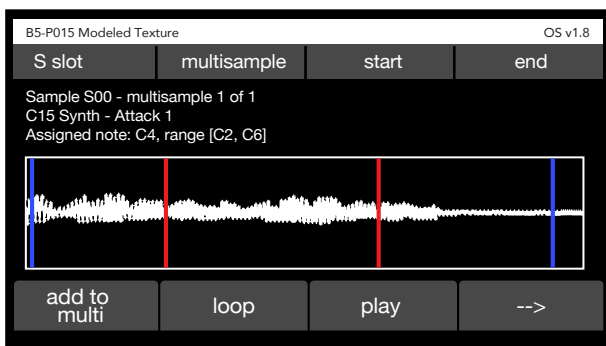

Sample Edit screen

4. Press soft button 1 (ADD TO MULTI).
5. To use an existing sample that is saved in memory, use soft knob 1 to select the sample.
6. Set the assigned note for the selected sample in the slot by pressing a key on the keyboard.
7. If you are adding multiple samples to the container (8 maximum) set each of their assigned notes as you load them to map them across the keyboard.
8. Press soft button 4 (SELECT) to add the sample to the multi-sample container.

## Using Samples in a Preset

Once you have imported and assigned one or more samples to a specific slot, you can use them in a program. You will use the WAVETABLE knob in the OSCILLATOR section of the 3rd Wave to locate them. Assigned multi-sample containers appear in the “S” category, which follows the virtual analog waveforms in the “A” category.

### *To use the sample(s) assigned to a slot in a program:*

1. In the OSCILLATOR section, turn the wavetable knob to scroll to the “S” category of sounds. This category lists the various multi-sample slots that you have created.
2. Select the sample slot containing the desired sample(s).
3. Play the keyboard to hear the sample.
4. Continue designing the sound by adjusting the filters, envelopes, modulation, effects and other parameters as you normally would.



If a sample is in use in a program, you can quickly edit it by pressing soft button 2 (SAMPLE) in the appropriate oscillator’s screen. The sample editing screen will appear. Here you can loop the sample, adjust its start and end point, edit its name, and more.

## Editing Samples

Once you have loaded samples in the 3rd Wave and assigned them to slots, you can edit them in various ways. This includes looping, changing tuning, and adjusting start or end points. These settings are not saved into the source sample itself, but per occurrence of the sample within a specific multi-sample slot.

This means that you can set various parameters for the same sample differently in different slots, or even in the same slot if the sample appears multiple times in that slot. You could, for example, change the start or end point of the sample, its loop settings, its tuning, and so on in each different occurrence. There are a maximum of eight multi-sample locations per slot.

The most effective way to edit and audition changes to a sample is to assign it to a multi-sample slot and create a program that uses it on one of the oscillators so you can play it from the keyboard as you make changes. Certain functions such as looping can only be fully auditioned this way. Refer to “Using Samples in a Preset” on page 42 for instructions on to do this.

Once a sample is assigned to a multi-sample slot and in use in a program, you can quickly edit it by turning the **WAVETABLE** knob on the oscillator that uses the sample then pressing soft button 2 (**SAMPLE**). The sample editing screen will appear. Here you can loop the sample, adjust its start and end point, edit its name, and more.

### **To edit a sample:**

1. Press the **GLOBAL** button and use soft knob 1 to scroll to the **MANAGE MULTISAMPLES** setting.
2. Turn soft knob 2 to select **GO**.
3. In the Sample Editing screen, use soft knob 1 to select the desired multi-sample slot, then use soft knob 2 to select the desired sample itself. The sample appears in the display.

## **Adjusting Start and End Points**

1. To adjust the playback start point of the sample, turn soft knob 3. Press play to hear the effect. The blue line at the beginning of the waveform in the display indicates the playback start point.
2. Press soft button 3 (**PLAY**) to hear the effect.
3. To adjust the end point of the sample, turn soft knob 4. The blue line at the end of the waveform the display indicates the playback end.
4. Press soft button 3 (**PLAY**) or play a note on the keyboard to hear the effect. (Make sure you are using a program that uses the current sample and are playing in a range where the current sample is active.)
5. Continue adjusting the start and end points as desired. When you are satisfied, save the program by pressing the **WRITE** button on the front panel. This will save the start and end into the multi-sample slot in addition to saving the program.

## Looping

To create and edit effective loops, you need to audition the sample by playing it on the keyboard. To do this you need to assign the sample to a multi-sample slot and use it in a preset so you can trigger it from the keyboard as you make changes. Refer to “Using Samples in a Preset” on page 42 for instructions on to do this.

Once a sample is in use in a preset, you can quickly edit it by turning the WAVETABLE knob on the oscillator that uses the sample then pressing soft button 2 (SAMPLE). The sample editing screen will appear. Here you can loop the sample, adjust its start and end point, edit its name, and more.

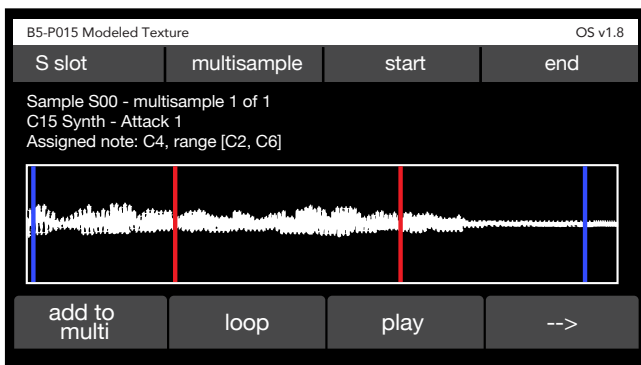

### ***To loop a sample in the sample editing screen:***

1. Press soft button 2 (LOOP) to access the looping screen.
2. To turn looping on, press soft button 2 (loop select). Press this button repeatedly to select the type of looping that you want.

The options are:

- **LOOPING OFF.** In the this mode, the sample will play from beginning to end as a “one shot.” It will not loop or repeat unless re-triggered.
- **LOOPING ON WHEN NOTE ON.** In the this mode, the note will continue looping while you hold a note. Once the note is released, looping stops and the post-loop segment of the sample (if present) will play.
- **LOOPING ALWAYS ON.** In this mode, the note will continue looping both while you hold a note and also once you release the note. This

allows very short samples to continue to play for as long as the release section lasts even if the sample itself is short.

3. When looping is on, red lines indicate the loop start and end points. To adjust these, use soft knob 3 (LOOP START) and soft knob 4 (LOOP END).
4. To edit the crossfade between the beginning and end of the loop, press soft button 3 (CROSSFADE).
5. Use soft knob 2 to choose the crossfade type.

The options are:

- **EQUAL VOLUME.** This option is well suited to material that is phase coherent — in other words, where the sound at the beginning and the end of the loop are similar in volume and waveshape. This option creates a linear crossfade that helps keep the overall volume constant during the crossfade.
  - **EQUAL POWER.** This option is well suited to material that is not phase coherent — in other words, where the sound at the beginning and the end of the loop are very different in volume and waveshape. This option creates a sinusoidal crossfade that is -3 dB in the middle of the fade. This helps keep the overall volume constant during the crossfade.
  - **OFF.** This option turns off crossfading. With crossfading off, you will hear an audible click when the loop occurs unless the audio is perfectly correlated and volume matched at the two loop points.
6. Use soft knob 2 to choose the crossfade length. Length is shown in milliseconds. The crossfade length can extend up to the full length of the loop.
  7. To audition the loop, play the 3rd Wave keyboard.
  8. To adjust the loop start and loop end points, Press soft button 1 to return to the sample edit screen.
  9. The red lines at the beginning and end of the sample indicate the loop start and loop end point.
  10. Use soft knob 3 to adjust the loop start point.
  11. Use soft knob 4 to adjust the loop end point.
  12. To audition the loop, play the 3rd Wave keyboard. (Make sure you are using a program that uses the current sample and are playing in a range where the current sample is active.)

13. Continue adjusting the loop start and end while auditioning the sample. If necessary try different crossfade types and crossfade lengths.
14. When you are satisfied, save the preset by pressing the **WRITE** button on the front panel. This will save the loop and crossfade setting into the multi-sample slot in addition to saving the program.

## Additional Parameters in the Sample Edit Screen

There are several additional parameters that you can access in the Sample Edit screen by using soft button 1 (left arrow) and soft button 2 (right arrow).

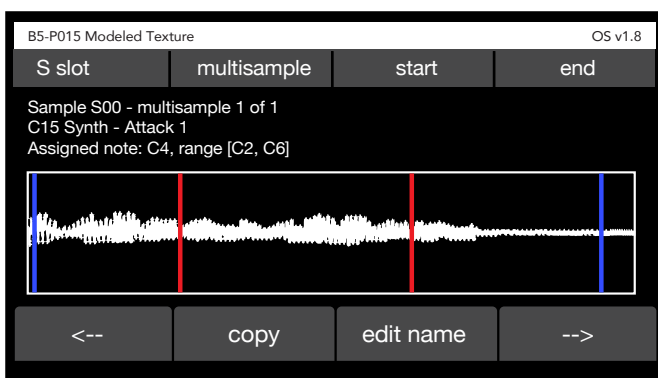

Sample Edit screen (page 2)

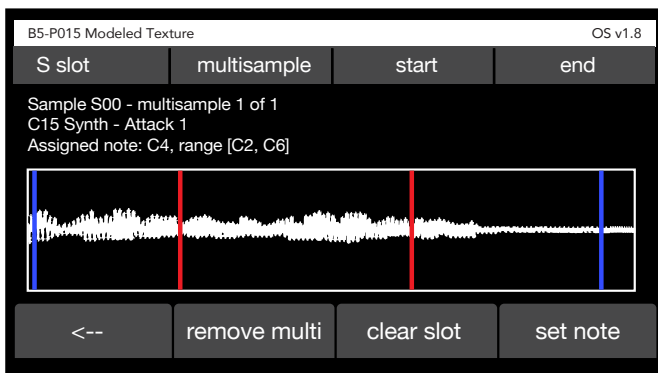

Sample Edit screen (page 3)

**COPY:** Copies all multi-samples to a new slot. This is important if you have multiple presets using the same multi-sample slot. If you make changes to the slot, all presets using it will change. In some cases, it is desirable to copy to a new slot if you want to change the sound and not affect other presets that may be using the same sample or multi-sample.

**EDIT NAME:** Allows you to change the name of the selected sample slot. To change the name of the slot hit the “edit name” button.

**REMOVE MULTI:** Deletes the selected multi-sample from the current slot.

**CLEAR SLOT:** Removes all of the multi-samples from the current slot.

**SET NOTE:** The parameters in this section allow you to change the tuning, assigned note, minimum note (lowest playable note), and maximum note (highest playable note) for the selected multi-sample.

The options in the SET NOTE screen are:

- **TUNING.** Allows you to fine tune the pitch of the sample. The range is -100 cents to +100 cents.
- **ASSIGNED.** To edit the assigned note, hold down the ASSIGNED button (soft button 2) while you press a key on the keyboard. Editing the assigned note will automatically adjust the min and max note depending on the other samples in the slot. By default, it splits the note range evenly from the next lower and higher samples. The maximum range (if no other samples are assigned) is two octaves above and below the assigned note location.
- **MIN.** Sets the minimum (lowest playable) note. This is useful for creating a specific key range for a particular sample in a multi-sample slot. You can manually set the minimum note by holding down the corresponding button and pressing a key on the keyboard. Note that each sample has a pitch transposition range of two octaves below the note value currently assigned as the maximum.
- **MAX.** Sets the maximum (highest playable) note. This is useful for creating a specific key range for a particular sample in a multi-sample slot. You can manually set the maximum note by holding down the corresponding button and pressing a key on the keyboard. Note that each sample has a pitch transposition range of two octaves above the note value currently assigned as the minimum.

## Backing Up and Restoring Samples and Sample Slots

Because sample memory on the 3rd Wave is limited, it is useful to be able to periodically backup and restore samples and the memory slots that use them. This allows you to create a variety of sample sets that you can swap out as needed when memory is full.

Note that samples and sample slots are different and must be exported and imported separately. When you export the sample slot, all data is included in its associated bin file, including the raw audio of the sample.

### ***To export individual samples as .wav files***

1. Connect your computer to the 3rd Wave's USB port using a USB cable.
2. On the 3rd Wave, press the GLOBAL button and use soft knob 1 to scroll to the EXPORT SAMPLE MEMORY TO WAV setting.
3. Turn soft knob 2 to select GO.
4. Select "Export sample memory to WAV" in the GLOBAL menu.
5. Press soft button 4 (OK) to begin exporting.
6. The 3rd Wave will save a .wav file for each sample.
7. On your computer, locate and open the 3rd Wave's AUDIO folder on your desktop.
8. Copy the exported .wav files onto your computer to store and archive them.

### ***To export sample slots:***

1. Connect your computer to the 3rd Wave's USB port using a USB cable. The 3rd Wave appears on your computer desktop as an external drive called "THIRDWAVE.".
2. On the 3rd Wave, press the GLOBAL button and use soft knob 1 to scroll to the EXPORT SAMPLE LIBRARY setting.
3. Turn soft knob 2 to select GO.
4. Press soft button 4 (OK) to begin exporting. The 3rd Wave will save a .bin file for each of its sample slots into its AUDIO folder.



5. On your computer desktop, locate and open the 3rd Wave's AUDIO folder.
6. Copy the exported .bin files onto your computer to store and archive them.

**To restore archived 3rd Wave samples from your computer:**

1. Connect your computer to the 3rd Wave's USB port using a USB cable. The 3rd Wave appears on your computer desktop as an external drive called "THIRDWAVE."
2. On your computer, locate the 3rd Wave .bin files that you previously exported and copy them into the 3rd Wave's AUDIO folder. Make sure only these files are present in the AUDIO folder. If there are other files, remove them before copying the archived .bin files.
3. On the 3rd Wave, press the GLOBAL button.
4. To import a single file, use soft knob 1 to scroll to the IMPORT MULTI-SAMPLE setting and turn soft knob 2 to select GO.
5. Alternatively, to import a multiple files, use soft knob 1 to scroll to the BULK MULTISAMPLE IMPORT setting and turn soft knob 2 to select GO. The files are imported in alphabetical order according to their file name.
6. Use soft knob 1 to select the multi-sample slot index you would like to overwrite.
7. Press soft button 4 (OK). The 3rd Wave imports the archived file(s).

# Low Frequency Oscillators

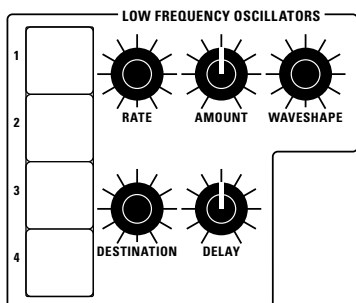

The Low Frequency oscillators

The four LFOs are oscillators that generate frequencies below the range of human hearing (although you can send any of them into the audio range if you increase up their frequency enough). The LFOs generate a variety of waveshapes, including triangle, sawtooth, reverse sawtooth, square, pulse, and random (“sample & hold”).

Use the LFOs to modulate parameters in the 3rd Wave and create many interesting effects. To create vibrato, for instance, send a triangle or sine wave to an oscillator. To create tremolo, send a triangle, sine, or square wave to the amplifier. To create an auto-wah effect, a triangle or sine wave to the filter cutoff.

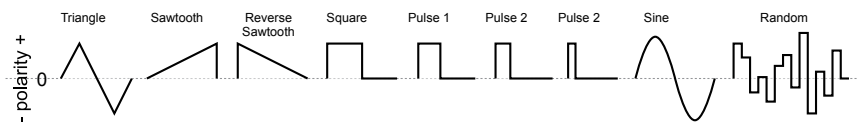

LFO waveshapes

## LFO Controls

**RATE:** (0-255) Sets the frequency of the selected LFO. If you want, you can sync the LFOs to the arpeggiator, sequencer, or MIDI clock for tempo-synced effects such as filter sweeps and so on.

**AMOUNT:** (-100 to +100) Sets the amount of LFO modulation routed to the selected destination. Setting an amount here applies the selected modu-

lation continuously. You can also use the modulation matrix to route an LFO to additional destinations and use a different modulation amount.

**SHAPE:** (Sine, Triangle, Reverse Saw, Saw, Square, Pulse 1, Pulse 2, Pulse 3, Random) This knob sets the waveshape of the selected LFO.

**DESTINATION:** Routes the selected LFO to one of the many modulatable destinations within the synthesizer. You can also use the modulation matrix to route an LFO to additional destinations.

**DELAY:** (0-100) Sets a variable amount of delay before the selected waveshape is applied. A simple use for this is to create a delayed vibrato effect.

**SYNC:** (on/off) (In the menus) When on, the LFO synchronizes with the master clock, which controls the arpeggiator, sequencer, and certain effects.

**NOTE RESET:** (on/off) (In the menus) Enabling Note Reset makes the LFO wave cycle reset each time you press a key. This is useful if you want to ensure that the full waveshape is applied each time you strike a key.

***There are many ways to make creative use of the LFOs:***

- Route the LFO to the **PITCH** parameter of the oscillators to create vibrato (TRIANGLE wave) or random pitches (S&H/RANDOM wave).
- Route the LFO's triangle wave to the filter's **CUTOFF** parameter and use a medium **FREQ** and **AMOUNT** setting to create a wah-wah effect, or use a slow **FREQ** setting and low **AMOUNT** setting to create subtle harmonic movement.
- Route the LFO's square wave to the amplifier's **ENV AMOUNT** parameter and use a medium LFO **FREQ** and **AMOUNT** setting to create a tremolo effect.
- Route an LFO to an oscillator's **WAVE OFFSET** parameter to make its timbre evolve.
- Route the LFO's triangle wave to the **TIME** parameter of the stereo delay and use a slow **FREQ** and low **AMOUNT** setting to create a chorus effect.



Any LFO can be routed to any destination (or multiple destinations) using the modulation matrix.

## Longer LFO Frequency Values in Sync Mode

The four LFOs on the 3rd Wave feature additional longer Frequency values when synced to the Arpeggiator/Sequencer clock. Previously the longest frequency setting was “whole” (whole note). The following additional values have been added:

- 6 beats
- 8 beats
- 16 beats
- 32 beats

### *To use longer LFO frequency values in Sync mode:*

1. Press one of the four front-panel LFO buttons.
2. In the display menu, press soft button 2 (MISC) to show the miscellaneous parameters.
3. Use soft knob 3 (SYNC) to set LFO sync to ON.
4. Press soft button 1 to show the main WAVE parameters.
5. Use soft knob 1 (FREQ) to select the desired LFO frequency.

Note that the longer LFO frequencies are available only when the LFO is synced to the Arpeggiator/Sequencer clock.

# Filters

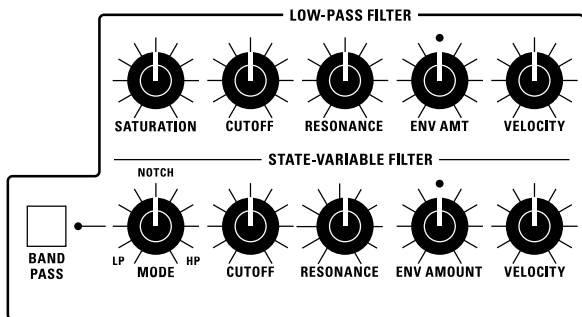

The Filters

If you recall, the oscillators produce the raw sound of the synthesizer. The filters do exactly what their name suggests: they take in this raw sound and filter something out — in this case, harmonic frequencies. This gives you the power to change the character of the raw sound.

The 3rd Wave has two separate filters: a 4-pole analog low-pass filter and a zero-delay, 2-pole digital state-variable filter.

Here's how they each work:

- **LOW-PASS FILTER:** This is a classic, 4-pole, 24db per-octave resonant filter that cuts out high frequencies and passes low frequencies.
- **STATE-VARIABLE FILTER:** This is a zero-delay, 2-pole, 12db per-octave resonant filter that can be continuously varied between low-pass, notch, and high-pass operation. It has a dedicated switch that enables Band-Pass mode. Each mode does what its name suggests. The State-Variable filter cannot self-oscillate. Another characteristic of the State-Variable filter is that increasing the amount of **RESONANCE** does not decrease the amount of low-frequencies (bass).

The best way to get a feel for what the filters do and how they sound is to give their Cutoff knob a good twist, with and without a bit of Resonance.

The two filters operate in series — the State-Variable Filter first, followed by the Low-Pass Filter. Using the two together, with different cutoff, resonance, and for the state-variable filter **MODE** settings creates a wide tonal variety. Try using the Mod Matrix to route a second envelope — Envelope 3 or 4 — to the state variable filter in addition to the standard Filter Envelope for some interesting effects.

## Low-Pass Filter Controls

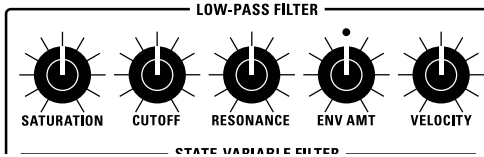

The Low-Pass Filter

**SATURATION:** (0-127) This overdrives the output of the Low-Pass Filter, making it possible to add harmonic distortion and additional warmth.

**CUTOFF:** (0-127) Sets the filter's cutoff frequency. High frequencies are cut and low frequencies passed, hence the name "low-pass."

**RESONANCE:** (0-127) Emphasizes a band of frequencies around the cutoff frequency. High levels of resonance can cause the filter to self-oscillate and generate its own pitch.

**RESONANCE COMPENSATION:** (On. Off) When On, increasing the Resonance setting does not decrease the amount of low-frequencies (bass response). When Off, increasing the Resonance setting decreases the amount of low-frequencies as is typical of a 24dB per octave resonant filter.

**ENV AMOUNT:** (-127 to +127) Sets the amount of modulation from the filter envelope to the filter's cutoff frequency. Any setting above zero means that each time you strike a key, the filter envelope controls how the filter opens and closes. Higher amounts more dramatically affect the cutoff frequency. This control is bipolar. Positive settings produce standard behavior. Negative settings invert the envelope.

**VELOCITY:** (0-127) Allows key velocity to influence filter frequency. When the VELO TO ENV parameter is set to ON in the Filter's MISC menu The harder you play, the more the filter will open and the brighter the sound will be. This control makes for more touch-sensitive sounds.

**KEY AMOUNT:** (0-127) (In the menus) Sets the amount of filter tracking from the keyboard to the filter's cutoff frequency. Any setting above zero means that the higher the note played on the keyboard, the more the filter opens. This adds brightness to higher notes. At zero, keyboard filter tracking is off and filter frequency is unaffected whether you play higher or lower on the keyboard.

## State-Variable Filter Controls

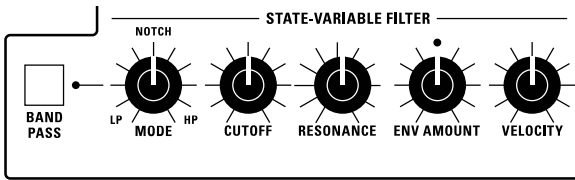

The State-Variable Filter

**BANDPASS:** This switch turns on Band-Pass filter mode. In this mode only a narrow band of frequencies (set with the Cutoff knob) is passed by the filter, while high and low frequencies on either side of the band are cut.

**MODE:** (0-127) This knob selects the state-variable filter's mode. It changes smoothly from low-pass to notch to high-pass operation. Each filter mode has its own characteristic sound.

**CUTOFF:** (0-127) Sets the filter's cutoff frequency. Each filter mode has its own characteristic operation and sound:

- Low-pass: passes frequencies below the cutoff frequency
- Notch: removes frequencies in a notch centered around the cutoff frequency
- High-pass: passes frequencies above the cutoff frequency
- Bandpass: passes a band of frequencies centered around the cutoff frequency

**RESONANCE:** (0-127) Emphasizes a band of frequencies around the cutoff frequency. Unlike the analog low-pass filter, the state-variable filter doesn't self-oscillate if you set Resonance to maximum.

**ENV AMOUNT:** (-127 to +127) Sets the amount of modulation from the filter envelope to the filter's cutoff frequency. Any setting above zero means that each time you strike a key, the filter envelope controls how the filter opens and closes. Higher amounts more dramatically affect the cutoff frequency. This control is bipolar. Positive settings produce standard behavior. Negative settings invert the envelope.

**VELOCITY:** (0-127) Allows key velocity to influence filter frequency. When the VELO TO ENV parameter is set to ON in the Filter's MISC menu The harder you play, the more the filter will open and the brighter the sound will be. This control makes for more touch-sensitive sounds.

***To hear the effect of the filter:***

1. Recall the Basic Program by pressing the GLOBAL button and using soft knob 1 to navigate to the SET INIT PROGRAM command, then turn soft knob 2 (GO).
2. Hold down a note and rotate the filter's CUTOFF knob. Notice how it cuts the high frequencies as you rotate counter-clockwise, making the sound of the oscillator less bright. If you turn the CUTOFF knob fully counter-clockwise you'll filter out all frequencies and hear nothing.
3. Return the CUTOFF knob to its halfway position, hold down a note again then turn the RESONANCE knob about halfway up.
4. Rotate the filter's CUTOFF knob again and listen to the sound change as a band of frequencies near the cutoff is amplified. This how to create a classic resonant filter sweep.

In the previous example, you controlled the filter cutoff by hand. In most cases, you will use the Filter Envelope to do this. To learn more about the Filter Envelope, see "Filter Envelope" on page 57.

## **Exploring the State-Variable Filter**

As its name suggests, the State-Variable filter can change its operational mode/state from low-pass, to notch, to high-pass, with a separate Band-Pass mode that you can activate using the BP (band-pass) button. This makes the State-Variable filter very versatile.



### **Exploring the State-Variable filter:**

1. Recall the Basic Program by pressing the GLOBAL button and using soft knob 1 to navigate to the SET INIT PROGRAM command, then turn soft knob 2 (GO).
2. Turn the MODE knob all way to the left so that the filter is set to LP (Low-Pass mode).
3. Hold down a note and rotate the filter's CUTOFF knob. Notice how it cuts the high frequencies as you rotate counter-clockwise, making the sound less bright.
4. Turn the filter's MODE knob to NOTCH and rotate the CUTOFF knob again. Listen to the effect as the filter cuts a band of frequencies centered around the cutoff frequency.
5. Now turn the filter's STATE knob to HP (high-pass) and rotate the CUTOFF knob again. Listen to the effect as the filter removes the low-frequencies from the sound.
6. Now press the BANDPASS button and rotate the CUTOFF knob again. This time, the filter removes frequencies above and below the cutoff frequency.
7. Finally, turn the resonance knob to its center positions and repeat steps 3-6 to hear the effect.

There are many intermediate states between the LP, NOTCH, and HP settings. This is one of the reasons that the State-Variable filter is so versatile.

## **Filter Envelope**

The 3rd Wave filter has a dedicated, 4-stage envelope generator (ADSR) with an additional DELAY parameter, which you can use to delay the onset of the envelope. The Filter Envelope is used to shape the harmonic characteristics of a sound by giving you filtering control over its attack, decay, sustain, and release stages.

Without an envelope, the filters would stay open or closed by the amount set by the Cutoff knob — and it wouldn't change over the duration of a

sound. Sonically that would be pretty boring. It's also not how instruments behave in the real world. In general, sounds produced by an instrument are brighter at their beginning (the attack stage) and grow mellow as they die out (the decay and release stages). In other words, their harmonic content changes over time. This is what the filter envelope is designed to emulate.

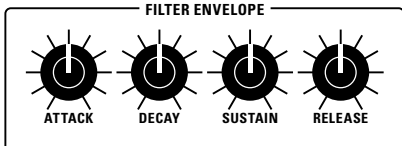

Filter Envelope

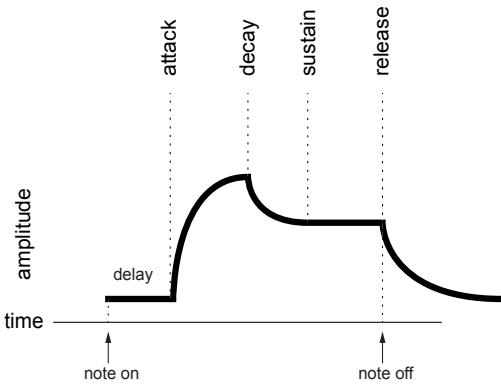

A typical 4-stage ADSR envelope

## Filter Envelope Controls

**ATTACK:** (0-127) Sets the attack time of the envelope. The higher the setting, the slower the attack time and the longer it takes for the filter to open from the level set with the filter `CUTOFF` knob to the level set by the filter envelope amount. Percussive sounds typically have sharp (short) attacks.

**DECAY:** (0-127) Sets the decay time of the envelope. After a sound reaches the filter frequency set at its attack stage, `DECAY` controls how quickly the filter then transitions to the cutoff frequency set with the `SUSTAIN` knob. The higher the setting, the longer the decay. Percussive sounds, such as synth bass, typically have shorter decays (and some low-pass filter resonance).

**SUSTAIN:** (0-127) Sets the filter cutoff frequency for the sustained portion of the sound. The sound will stay at this filter frequency for as long as a note is held on the keyboard.

**RELEASE:** (0-127) Sets the release time of the envelope. This controls how quickly the filter closes after a note is released.

**DELAY:** (0-127) Sets a variable amount of delay before the envelope is triggered. This is particularly useful when creating multi-part sound if you want the onset of one the parts to be delayed in relation to the others.

**SHAPE MODE** (on Misc page of envelope): (Exponential, PPG) Sets the response of the envelope. You can choose between standard, exponential response, or “PPG” response. The PPG’s envelope’s were rather unique in their behavior. The best way to get a feel for their behavior is to try them with a variety of Attack, Decay, and Release settings.

## Amplifier Envelope

After passing through the filters, a synthesized sound goes into an amplifier, which controls its overall volume. Like the Filter, the Amplifier has a dedicated 4-stage envelope generator (ADSR) with an additional DELAY parameter, which you can use to delay the onset of the envelope.

The Amplifier Envelope is used to shape the volume characteristics of a sound over time by giving you control over its attack, decay, sustain, and release stages. Along with the filter envelope, this is one of the most important factors in designing a sound.

Without a volume envelope, the volume of a sound wouldn’t change over the duration of a note. It would begin immediately, remain at its full volume for the duration of the note, then end immediately when the note was released. Again, not very interesting sonically and not typically how real instruments behave.

In the real-world, for example, the main difference between the sound of the wind and the sound of a snare drum is that they have very different volume envelopes. Otherwise, they are both white noise. Wind has a slow attack, a long sustain, and a long decay and release. A snare drum has a sharp attack, no sustain, and little decay or release. But they are both fundamentally white noise.

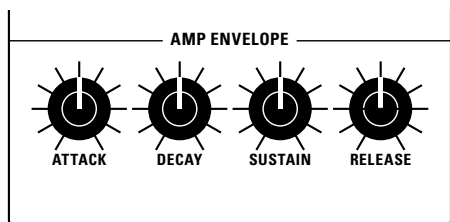

Amplifier Envelope

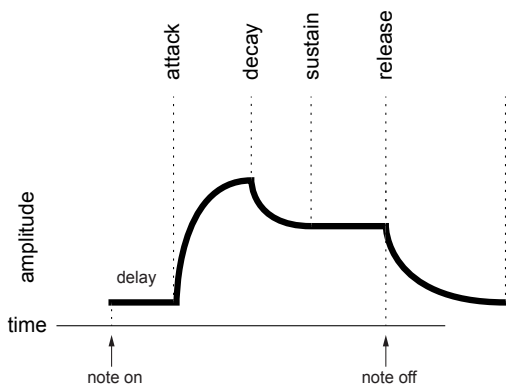

A typical 4-stage ADSR envelope

## Amplifier Envelope Controls

**ATTACK:** (0-127) Sets the attack time of the envelope. The higher the setting, the slower the attack time and the longer it takes for the filter to open from the level set with the filter *CUTOFF* knob to the level set by the filter envelope amount. Percussive sounds typically have sharp (short) attacks.

**DECAY:** (0-127) Sets the decay time of the envelope. After a sound reaches the filter frequency set at its attack stage, **DECAY** controls how quickly the filter then transitions to the cutoff frequency set with the **SUSTAIN** knob. The higher the setting, the longer the decay. Percussive sounds, such as synth bass, typically have shorter decays (and some low-pass filter resonance).

**SUSTAIN:** (0-127) Sets the filter cutoff frequency for the sustained portion of the sound. The sound will stay at this filter frequency for as long as a note is held on the keyboard.

**RELEASE:** (0-127) Sets the release time of the envelope. This controls how quickly the filter closes after a note is released.

**ENV AMOUNT:** (0-127) (In the menus) Sets the amount of modulation from the Envelope to the VCA. In most cases you will probably want to set this fully clockwise for maximum VCA volume. If you experience signal clipping, try reducing the **ENV AMOUNT**.

**DELAY:** (0-127) Sets a variable amount of delay before the envelope is triggered. This is particularly useful when creating multi-part sound if you want the onset of one the parts to be delayed in relation to the others.

**SHAPE MODE** (on Misc page of envelope): (Exponential, PPG) Sets the response of the envelope. You can choose between standard, exponential response, or “PPG” response. The PPG’s envelope’s were rather unique in their behavior. The best way to get a feel for their behavior is to try them with a variety of Attack, Decay, and Release settings.

# Envelopes 3/4

The 3rd Wave has two additional 5-stage envelope generators (Delay+ADSR). These are useful modulating other 3rd parameters according to the shape of the envelope. Routing an envelope to an oscillator's frequency, for example, causes the oscillator's pitch to rise and fall according to the contour of the envelope.

These extra envelopes can be routed to any of the modulation destinations in the mod matrix. In addition, the extra envelopes can repeat (loop) using the ENV REPEAT function in the menu. This is useful for cyclical 4-stage modulation.

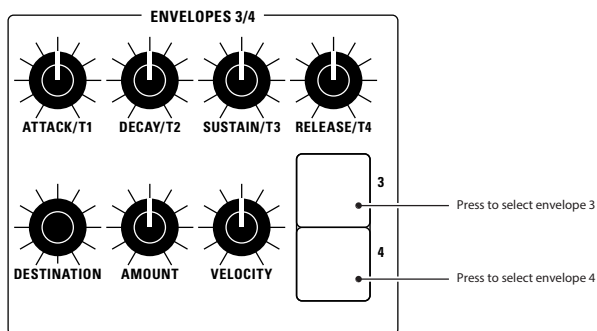

Envelopes 3/4

## Envelope 3/4 Controls

**ATTACK/T1:** (0-127) Sets modulation time for the envelope attack/stage-1. The higher the setting, the longer it takes for the envelope to travel to decay/stage-2.

**DECAY/T2:** (0-127) Sets modulation time for the envelope decay/stage-2. The higher the setting, the longer it takes for the envelope to travel to sustain/stage-3.

**SUSTAIN/T3:** (0-127) Sets modulation level for the envelope sustain/stage-3. The mod level will stay at this setting for as long as a note is held on the keyboard.

**RELEASE/T4:** (0-127) Sets modulation level for the envelope release/stage-4. This controls how quickly the modulation reaches its zero value after a note is released.

**DESTINATION:** (various) Selects a modulation destination for the Envelope.

**ENV AMOUNT:** (-127 to +127) Sets the amount of modulation from the envelope to the chosen destination. The modulation amount can be positive or negative, allowing for inverted envelope control.

**VELOCITY ON/OFF:** (on/off) (In the menus) This enables keyboard velocity to modulate the Envelope Amount.

**DELAY:** (0-127) (In the menus) Sets a delay between the time the envelope is triggered (note on) and when the attack portion actually begins.

## Modulation

Although the overall sound of the 3rd Wave is determined by its oscillators and filters, much of its power to make truly unique sounds comes from creative use of modulation. Modulation is the process of routing one parameter (i.e. a control voltage) to another in order to change the way the targeted parameter behaves.

The concept is simple:

1. Choose a source.
2. Choose a destination.
3. Set an amount. The amount can either be positive or negative.

You already understand and apply the concept of modulation whenever you use the filter envelope to control the filter's cutoff frequency. In this case, the modulation *source* is the filter envelope (or more precisely, any of its controls, such as attack, decay, sustain, or release). The modulation *destination*, is the filter's cutoff frequency. The modulation *amount* is set with the ENV AMOUNT knob.

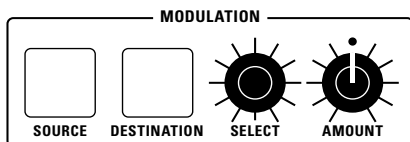

The Modulation section

## Modulation Controls (in Display)

**SOURCE:** Selects a modulation source as shown in the display menu.

**DESTINATION:** Selects a modulation destination as shown in the display menu.

**SELECT:** Selects among the 16 modulation slots as shown in the display menu.

**AMOUNT:** (-127 to +127) Sets the modulation amount. Modulation can be either positive or negative.

## Modulation Examples

Below are some modulation scenarios that illustrate how to use the modulation matrix. The examples provide full, step-by-step instructions for clarity.

### To program a mod wheel to add vibrato:

1. In the LOW FREQUENCY OSCILLATORS section, set LFO 1 to TRIANGLE and set FREQUENCY to 130.
2. Set DESTINATION to OSC ALLFREQ. Set AMOUNT to 0. (You will control the amount with the mod wheel of your MIDI controller.)
3. In the MODULATION section, press the SOURCE button. Use soft knob 1 knob to scroll to Mod Slot 1 if it's not already displayed.
4. Use soft knob 2 to set modulation SOURCE to MOD WHEEL.
5. Use soft knob 3 to set the modulation DESTINATION to LFO 1 AMOUNT.



6. Use soft knob 4 to set the modulation **AMOUNT** to 40.
7. Hold down a note on the keyboard and turn the mod wheel on your MIDI controller. You should hear vibrato.



Use **PRESSURE** as the modulation source instead of the mod wheel in the previous example to add vibrato with key pressure/aftertouch.

## To use a mod wheel to control the filter cutoff:

1. In the **MODULATION** section, press the **SOURCE** button. Use soft knob 1 next to the display to scroll to Mod Slot 1 if it's not already displayed.
2. Use soft knob 2 to set modulation **SOURCE** to **MOD WHEEL**.
3. Use soft knob 3 to set the modulation **DESTINATION** to **LOWPASS CUTOFF**.
4. Hold down a note on the keyboard (or press the **HOLD** button and play a note on the keyboard) and turn the mod wheel on your MIDI controller.
5. Use soft knob 1 to select the **AMOUNT** field. Use the soft knob 4 to set the amount to your preference. Higher **AMOUNT** settings cause the filter to open wider the further you push the mod wheel. A negative amount setting will close the filter the further you push the mod wheel.



Use **PRESSURE** as the modulation source instead of the mod wheel in the previous example to open the filter (positive **AMOUNT**) or close the filter (negative **AMOUNT**) with key pressure/aftertouch.

## Other modulation ideas:

- Route **ENV 3** to **OSC ALL FREQ** to create a rising or falling pitch effect each time you press a key. This technique is often used to create the “attack pitch blip” effect in classic synth brass sounds. The shape of the envelope controls the pitch rise and fall.
- Route an **LFO** to **PAN POSITION** to create an auto-panning effect. Panning width is controlled by the modulation amount. Panning speed is controlled by the LFO frequency. Add a second mod path to control the LFO speed with a Mod Wheel for a rotating speaker spin-up/spin-down effect. Enable the chorus effect and set up a third mod path to control **EFFECT MIX** with a mod wheel for even better results.

# Effects

The 3rd Wave allows you to add two effects to any program. In stacked sounds, each layer can have its own effect.

Effects settings are saved individually with each program. Time-based effects such as the delays can be synchronized to the arpeggiator, sequencer, or MIDI clock to produce repeats that occur on the beat.

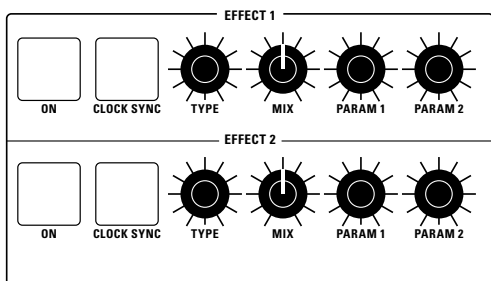

The Effect section

## Effects

- BBD Delay - vintage bucket-brigade emulation
- Stereo Delay - classic stereo delay
- Tape Delay - classic tape delay
- Chorus - vintage chorus
- Phaser - vintage 6-stage phaser, high feedback
- Flanger - vintage through-zero flanger, high feedback
- Ring Mod - classic ring modulator
- Distortion - digital distortion (analog emulation)
- Room - classic digital reverb with adjustable size, pre-early reflections, and cutoff
- Hall - classic digital reverb with adjustable size, pre-early reflections, and cutoff
- Superplate - digital reverb with adjustable size, pre-delay and cutoff

## Effects Limitations in Multi-Part Programs

All effect combinations are possible on the first two patches of a multi-part program. In other words, you can run any two effects that you want on Part 1 and Part 2.

However, some effects take much more processing power than others. As a result, there are a couple of effect combinations that could cause the 3rd Wave to exceed its processing limit and behave unpredictably. This is true in a 3-part or 4-part program.

### ***Here are some guidelines:***

- If you use the Tape Delay on both Part 1 and Part 3, (or both Part 2 and Part 4), only one of these parts can have a second effect.
- If you use the Room or Hall reverbs on both Part 1 and Part 3, (or both Part 2 and Part 4), you can't also use the Leslie Speaker or the Distortion effect in both of the other locations. (On other words, if Part 1 has the Leslie effect and the Hall effect, and Part 3 has the Hall effect, that is acceptable. But you can't use both Leslie and the Hall on both Part 1 and Part 3).

### ***To use effects:***

1. In the EFFECTS section, press EDIT button (1 or 2) to select the effect that you want to edit.
2. Press the ON/OFF switch to turn on the effect.
3. Turn the TYPE knob to choose an effect, depending on which you want to apply and configure.
4. Turn the MIX knob to blend in a good amount of the processed signal. You'll want to be able to clearly hear the effect when you tweak its settings. You can dial it down afterward.
5. Use the PARAM 1 and PARAM 2 knobs to adjust the effect's parameters to your taste. See the "Effects Parameters" table for details on the adjustable parameters of each effect type.
6. Finally, adjust the MIX knob again to optimize the amount of the effect. Full left is completely dry. Full right is completely wet (a 100% processed signal).

## Effects Controls

**ON/OFF:** Turns the effect on or off.

**CLOCK SYNC** (on Misc page of Effects): (see table below) When a delay effect is chosen, this enables syncing of the timed delay repeats (feedback) to the arpeggiator, sequencer, or MIDI clock. When **CLK SYNC** is on, delay time (parameter 1) provides the following values:

Value	Delay Time
Whole	4 beats
Half dot	3 beats
Half	2 beats
Quarter dot	1 1/2 beats
Quarter	1 beat
Quarter triplet	1 1/3 beats
8th dot	3/4 of 1 beat
8th	1/2 of 1 beat
8th triplet	1/3 of 1 beat
16th dot	3/8 of 1 beat
16th	1/4 of 1 beat



Maximum delay time is 1 second. The combination of longer synced delay times with slower tempos can result in delay times that would be greater than 1 second. When that happens, the delay time is divided by 2 until it no longer exceeds the 1 second limit. For example, if the BPM is set to 60 and Delay Time (Parameter 1) is set to Half, the expected delay time would be 2 seconds. The actual delay time will be 1 second (i.e. 2 seconds divided by 2).

**TYPE:** Selects the effect type.

**MIX:** (0-127) Sets the balance between the processed (wet) signal and unprocessed (dry) signal. Full left is completely dry. Full right is completely wet.

**PARAMETER 1:** (0-255) Variable, depending on the effect — This knob adjusts parameter 1 for the chosen effect. Each effect has two adjustable parameters, which differ depending on the effect.

**PARAMETER 2:** (0-255) Variable, depending on the effect — This knob adjusts parameter 2 for the chosen effect. Each effect has two adjustable parameters, which differ depending on the effect.

## Effects Parameters

Effect Type	Parameter 1	Parameter 2	Parameter 3
BBD Delay	delay time	feedback amount	cutoff
Stereo Delay	delay time	feedback amount	cutoff
Tape Delay (Echoplex)	time	feedback	wow & flutter head align Rec level tape hiss
Chorus	depth	rate	tone
Phaser	depth	rate	feedback
Flanger	depth	rate	feedback
Distortion	gain	tone	output level
Leslie speaker	drive	speed	distance
Ring Mod	frequency	low-note pitch tracking on/off	carrier
Room Reverb	reverb time	cutoff	early reflection amount
Concert Hall Reverb	reverb time	cutoff	early reflection amount
Room Reverb	reverb time	cutoff	pre delay

# Arpeggiator

When you turn on the arpeggiator and hold a chord, the synthesizer will play a pattern based on the individual notes you hold. Choose a mode (up, down, random, etc.), an octave range (1, 2, or 3), and a tempo, then pair it with an appropriate sound and explore.

While you hold down a chord, pressing any additional notes will add those notes to the arpeggio. You can change chords and notes and the arpeggio will continue to play as long as at least one note is always held. You can also use the HOLD feature with the arpeggiator. When you enable HOLD, you can release the notes on the keyboard and the arpeggio will continue to play — with any additional notes that you play added to the arpeggio.

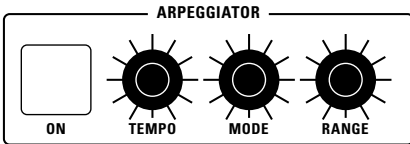

The Arpeggiator controls

## **To use the arpeggiator:**

1. Press the arpeggiator ON/OFF switch to turn it on.
2. Hold down one or more notes on the keyboard. The arpeggiator plays them according to the settings you've chosen.
3. To latch arpeggiation on (so that you don't have to continuously hold down notes) press the HOLD button.
4. Adjust settings (in the display) such as TEMPO, MODE, and RANGE.

## Arpeggiator Controls

**ON/OFF:** Turns the arpeggiator on and off.

**BPM:** (20-210) Sets the tempo for the arpeggiator in BPM (beats per minute). When LFO SYNC is enabled on the low-frequency oscillator, or CLOCK SYNC is enabled in the Effects section, the BPM rate affects the LFO frequency and/or delay effect. When syncing to an external MIDI clock source, the BPM setting has no effect.

**MODE:** (up, down, up+down, random, assign) Selects among the various arpeggiator modes shown in the display. You can scroll through these and choose their settings with the the soft knobs and soft buttons. See the table below for details on each mode.

Mode	Behavior
Up	Plays from lowest to highest note
Down	Plays from highest to lowest note
Up + Down	Plays from lowest to highest and back to lowest
Random	Plays notes in random order
Assign	Plays notes in the order the keys were pressed

**RANGE:** (1 octave, 2 octave, 3 octave) Set to 1 octave, only the held notes are arpeggiated. Set to 2 octaves, the held notes and the notes one octave above them arpeggiate. Set to 3 octaves, the held notes and the notes one and two octaves above them arpeggiate.

**NOTE VALUE:** (see table below) Selects a basic note value relative to the Tempo/BPM. See the table.

Value	Delay Time
Whole (1)	4 beats
Half dot (2D)	3 beats
Half (2)	2 beats
Quarter dot (4D)	1 1/2 beats
Quarter (4)	1 beat
Quarter triplet (4T)	1 1/3 beats
8th dot (8D)	3/4 of 1 beat
8th (8)	1/2 of 1 beat
8th triplet (8T)	1/3 of 1 beat
16th dot (16D)	3/8 of 1 beat
16th (16)	1/4 of 1 beat

**HOLD LATCH MODE:** (normal. chord) Controls the behavior of the arpeggiator when the HOLD button is on. In NORMAL mode, playing new notes will add them to the arpeggio. In CHORD mode, playing new notes will replace the previous notes. To access this feature, press soft button 4 in the Arpeggiator screen.

# Sequencer

The 3rd Wave Sequencer is a pattern-based sequencer. It provides one sequence per each of its 4 multi-parts. Each sequence can have up to 24 different patterns of up to 32 measures each.

You can also record parameter automation to have the Sequencer control the Filter's cutoff frequency or other parameters as a sequence plays.

The 3rd Wave's sequencer also features Song mode. You can arrange any of the 24 patterns in a sequence into a song of up to 24 sections. Each section can repeat up to 64 times and the entire song can be looped to endlessly repeat.

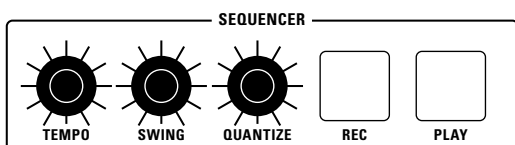

The Arpeggiator controls



When using a multi-part program, the Sequencer dynamically allocates available voices as needed. For example, if you have a four part program with sequences on each part, and 8 notes are being used by part 1, all 8 voices will play as long as the other three parts of the sequence aren't using more than 16 voices.

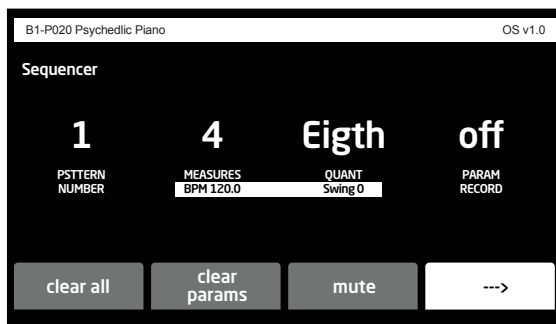

The Sequencer controls



## Creating a Pattern

A sequence can have up to 24 different patterns.

### **To record a pattern:**

1. Select a program.
2. In the Sequencer section, press any button to show the Sequencer controls in the main display.
3. Pattern 1 is selected by default. If you want to record a different pattern, use soft knob 1 to select a different pattern to record.
4. Use soft knob 2 to set the number of measures in the pattern.
5. Use soft knob 3 to set a quantization value. This will force the notes that you play to align to the chosen value. You can also set quantization to OFF. When off, the Sequencer will record the notes exactly as you play them without correcting their timing.



You can change the Quantize setting even after you have recorded a pattern. The Sequencer records any notes you play exactly as you play them and applies quantization separately.

6. Press the RECORD button. It flashes indicating it is ready to record.
7. Press the PLAY button. The click track plays a 4-beat count in. Press the TAP TEMPO button twice to set a tempo or in the display, use the BPM control (soft knob 1) to adjust the tempo as necessary.
8. When the click/sequence loops around to the beginning of measure 1, play a series of notes or chords on the keyboard. You can continue to add (overdub) notes to the sequence as it repeats.
9. If you make a mistake, press soft button 1 (CLEAR ALL) then repeat steps 6 - 8 to play the notes correctly.
10. To stop recording, press the RECORD button.
11. To stop playback, press the PLAY button.
12. To save the sequence, save the program by pressing the WRITE button twice.

### **To temporarily mute a pattern as it plays:**

- As the sequence plays, press and hold soft button 3 (MUTE) in the Sequencer's main menu. The Sequencer mutes playback of the active parts as long as you hold down the button.

## Creating a Song

After you have recorded several patterns, you can arrange them into a song. Each Song can contain up to 24 patterns and each pattern can repeat up to 64 times.

### ***To create a song:***

1. In the Sequencer section, press any button to show the Sequencer controls in the main display.
2. In the sequencer menu in the main display, press soft button 4 (right arrow). Additional Sequencer parameters appear.
3. Press soft button 3 (SONG). The Song parameters appear. Here you will arrange the patterns that you have recorded and specify how many times each pattern repeats.
4. Press soft button 2 to turn Song mode on.
5. Use soft knob 1 to select the song section (1-24). This control defaults to section 1.
6. Use soft knob 2 to select the song pattern number (1-24). This control defaults to Pattern 1.
7. Use soft knob 3 to set the Play Count (1-64). This is the number of times that pattern will repeat before moving to the next section/pattern.
8. If you want the song to loop, press soft button 3 (LOOP) and the song will loop as long as the Sequencer's PLAY button is on.
9. When you have finished arranging the patterns in the song, make sure Song mode is on, then press the Sequencer's PLAY button to begin song playback. (If Song mode is off, the Sequencer will play a single pattern, since this is its default mode of operation.)
10. To save the sequence, save the program by pressing the WRITE button twice.

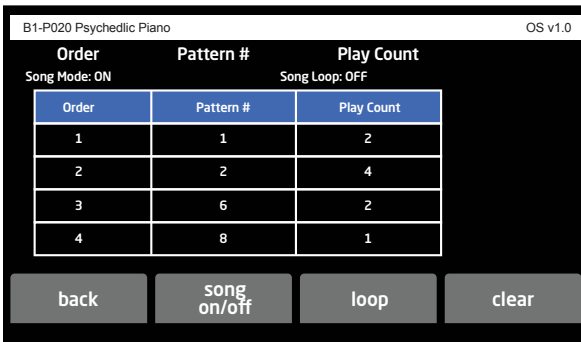

The Song controls

***To temporarily mute a song as it plays:***

- As the song plays, press and hold soft button 3 (MUTE) in the Sequencer’s main menu. The Sequencer mutes playback as long as you hold down the button.

## Sequencing Parameter Changes

The Sequencer makes it easy to record parameter changes in real-time as part of any of 24 patterns. To do this, simply turn on PARAM RECORD in the Sequencer menu, then begin recording as you normally would. Then adjust front-panel controls such as filter cutoff, noise level, envelope settings, or other parameters.

As the sequence plays, the Sequencer records the changes to the parameter and incorporates them into the sequence. Be aware of where and when the sequence loops back around to its beginning since the Sequencer continues to record (and possibly overwrite) any parameter changes you make as it repeats.

***To sequence parameter changes:***

1. Start playback of an existing sequence by pressing the PLAY button in the Sequencer section.
2. Use soft knob 4 to set PARAM RECORD to ON.
3. Press the RECORD button in the Sequencer section.
4. As the sequence plays, adjust a parameter (such as filter cutoff).

5. If you want to clear parameter automation in the pattern, press soft button 2 (CLEAR PARAMS) all parameter sequencing is erased.
6. To stop recording, press the RECORD button.
7. To stop playback, press the PLAY button.
8. To save the sequence, save the program by pressing the WRITE button twice.

The Sequencer continuously updates the changes you make as the sequence loops. As long as the sequence continues to play and record you can keep adjusting that parameter or additional parameters. If you stop moving a parameter knob, the Sequencer stops updating the automation and preserves whatever automation is already recorded.



You can also use the Sequencer to record per-part changes in volume, pan, and tuning in multi-part presets.

## Copying a Pattern

You can copy one pattern to another. Both the notes and any parameter automation in a pattern are copied.

### ***To copy a pattern:***

1. In the sequencer menu in the main display, press soft button 4 (right arrow). Additional Sequencer parameters appear.
2. Press soft button 2 (COPY). In the screen that appears, use soft knob 3 to choose the pattern you want to copy.
3. Use soft knob 3 to choose the destination pattern.
4. Press soft button 4. The pattern is copied to the destination.

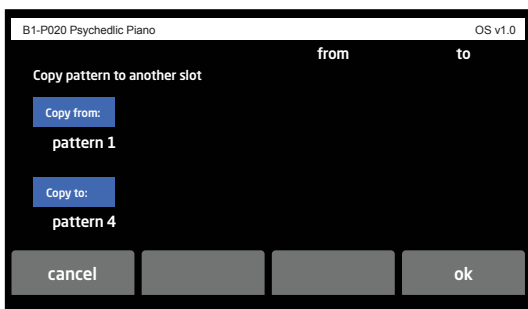

Copying a pattern

## Creating and Playing Independent Sequences for Each Multi-Part

As of version 1.8e, the sequencer will always treat the patterns recorded for each part independently. Previously, it would only do this if one part was active at a time. Now, whether you record the notes together with more than one part active or you record them separately, the sequencer will treat the pattern for each part independently like they are 4 separate tracks in a recording. You can also clear the recordings for each part separately by using the `CLEAR PART`, `CLEAR PARAMS`, and `CLEAR NOTES` buttons. These buttons will clear whichever parts are active in the multipart section. Use the `CLEAR ALL` button to remove the entire recording for all 4 parts.

# Pan Spread

Pan Spread pans the audio output of a 3rd Wave program in the stereo field individually per voice. With `PAN SPREAD` set to zero, all voices are panned in the middle (monophonic). As you turn `PAN SPREAD` to the right, the audio output of each voice is gradually moved away from the center. Every other voice goes in a different direction. This creates a wide stereo field as you play the program. Any modulation to Pan will individually move each voice from its static position as set by the `PAN SPREAD` setting.



The Pan Spread knob

## More About Panning

You can modify the panning of a voice using either the `PAN SPREAD` knob (fully left means no panning from voice to voice, and fully right means full hard panned movement of -50 and +50 with each new voice), or by using the `PAN` parameter in the multi-part pan screen (-50 to +50 for hard left and hard right with 0 in the center), or by using `PAN POSITION` as a modulation destination.

All three interact to determine the final pan behavior of the voices in a program.

It is important to understand what happens if you have pushed a voice all the way to -50 or to +50 (hard left or right pan positions). If the three ways of modulating the pan position cause you to go past either -50 in the negative direction or positive 50 in the positive direction, the pan position will wrap around in the opposite direction and keep going.

For instance, if you have the multi-part pan position set at +50 then you modulate this with a sine wave LFO, the positive part of the sine wave would normally have no effect, since the pan position is already at +50. But with this wrap around behavior, the positive part of the sine wave will make the pan position go back down toward zero. If the amount for the LFO in this example is set to 64, (half of the amount allowed), then the positive part of the sine wave would make the position go from +50 back down to 0 since it has wrapped around by 50 (half of the amount allowed). The negative part of the sine wave would take away from +50, and therefore also cause the position to move down to 0 at the most negative part of the sine LFO.

Since you have three ways to move the pan, (multi-part position, pan pot, and modulation), with this ability to wrap around, the pan will always move even if one of the three position methods put you at an extreme left or right position.

## The Wave Surfer

The Wave Surfer is a control that moves through all three wavetables at the same time. As long as each oscillator has a wavetable selected and not an analog waveform (A00 to A06), then you will move through the wavetable as you turn the Wave Surfer knob.

### WAVESURFER

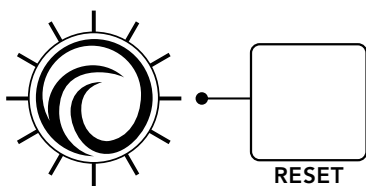

The Wave Surfer knob

When you turn the Wave Surfer control you are actually changing the waveform position in each of the oscillators. Each increment of the Wave Surfer moves forward or backwards one position from the offset that you have selected for each of your three wavetables with the `WAVE OFFSET` parameter.

When you move the wave surfer the current position (and wave offset) of each of the oscillators appears in the main display. When you turn the Wave Surfer Knob, you will see the wave positions change according to the offset that the Wave Surfer applies.

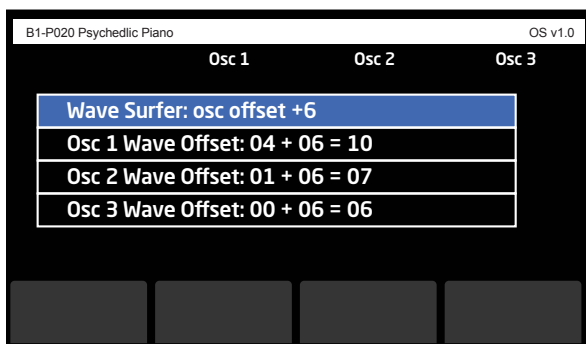

Wave Surfer controls

This page also gives you the option to change the base wave offset for each of the three oscillators independently. This is the same as changing the `WAVE OFFSET` parameter directly on each of the oscillators.

Turn the Wave Surfer quickly to go through the wavetables and “surf” the waves. Depending on the wavetables that you have chosen, you will hear either subtle or dramatic changes.

Pressing the `RESET` button sets the Wave Surfer back to zero. The Wave Surfer’s range is from -63 to 63. If you reach the end of any wavetable it will stop at 63 for that selection.

Since this control has a range of -63 to 63, the starting point is affected by the offset that has been set into the wavetable. The negative range is used to go from a high offset back down to zero. Once you have reached zero, it will not go any lower. If you reach the end of any wavetable, it will stop at 63 for that selection.

The only exception is with the `P` wavetables. If you have the `UPPER WAVETABLE` setting enabled in the `WAVE FLOW` menu (press the `WAVE FLOW` button). If you move the Wave Surfer knob beyond the 64th wave position, (position 63), you will hear the `P` wavetable move into the upper wavetable, which is table `P30`.



## About Wave Flow and Upper Wavetables

The PPG 2.2 and 2.3 didn't have interpolation when switching between waveforms in the wavetable. In addition, they didn't stop if you modulated past the 64th position in the wavetable, (0 to 63). To accommodate this, the PPG had what was called an upper wavetable, (wavetable P30), which you would spill over to if you modulated past the end.

In addition, every PPG wavetable actually only had 60 waveforms that were different — and the last 4 waveforms were always triangle, pulse width square, normal square, and sawtooth. Since these 4 waveforms have nothing to do with the rest of the table, if you went beyond the end into the upper wavetable, a click/discontinuity would occur as you went through positions 60 to 63.

On the 3rd Wave this only applies to “P” wavetables, which were derived from the original PPG wavetables. If you don't want to this boundary and walk into wavetable P30 as you would on the PPG, turn off the `USE UPPER WAVETABLE` option by pressing the `WAVE FLOW` button. In the screen that appears, use soft knob 1 to set this to `OFF`. When off, the 3rd Wave will only sweep through the first 60 wave positions then stop without going into the 8-bit upper wavetable “analog” waveforms.

Note that the “U” waves don't have this oddity. They extend to 64, (0 to 63), then stop with any upper wavetable waveforms.

You can test this by moving one of the PPG factory patches using the Wave Surfer knob. It will show you the offset number. When you reach 60 to 63, you will hear the waveform change drastically on any of the P wavetables as long as that Upper Wavetable function is turned on.

Finally, the “A” waveforms, which are analog modeled waveforms, are not the 8-bit PPG-style waveforms, but correct spline-interpolated models. If you want to use high-resolution, high-fidelity analog waveforms, use these. But if you want to use 8-bit PPG emulations of analog waveforms use the last 4 positions in the “P” wavetables. They will sound harsher (with aliasing and imaging), but that might be what you want. Remember to turn off the wave envelope if you want to use one of these last 4 as an “analog” waveforms. Set the wave offset from one of the positions from 60 to 63, turn off the wave envelope, and the waveform position will not move. You now have a classic, 8-bit aliased, PPG “analog” waveform.

# Creating Custom Wavetables

The 3rd Wave has 48 User wavetables (the “U” set). These are 64-wave-shape, high-resolution (96 kHz) anti-aliased wavetables. They were created specifically for the 3rd Wave by our team of sound designers using the built-in Wave Maker tool.

In addition to these 48 wavetables, the built-in Wave Maker utility allows you to create and load an additional 16 of your own custom waves. These will fill slots U48 - U63.

If you want, you can also use the Wave Maker to overwrite any of the 48 factory user waves — though this will impact any presets that use them.

To create your own custom User wavetables you will use the Wave Maker. First you need to import audio into the 3rd Wave. There are three ways to do this.

## ***To import audio into the 3rd Wave:***

- Connect an audio source to the rear-panel audio in using an unbalanced, ¼-inch audio cable and record that audio input using the Make Waves button and associated menu commands.

or

- Use an audio recording application such as Audacity, Logic Pro, Pro Tools, or similar audio recording application to create a 96 kHz, 16-bit or 24-bit monophonic .wav format audio file then copy it to the 3rd Wave’s AUDIO directory using your computer and a USB cable.

or

- Use an audio recording application such as Audacity, Logic Pro, Pro Tools, or similar audio recording application to create 64 single-cycle waveforms at 96 kHz and 1024 samples each. Then, using Audacity or other audio editing application, arrange them back to back in a .wav file. If you import this, the automatic procedure is bypassed and it imports the wavetable just as you created it, since its length is already correct. Be aware that you must import a .wav file that is exactly 65536 samples in length:  $64 \times 1024 = 65536$ .

## Some Technical Details About the Wave Maker

Before you use the Wave Maker, it's useful to know how it works. As explained earlier, a wavetable has waveforms that are a single cycle. A single-cycle waveform contains a certain number of samples before it repeats. The number of samples in the cycle is called its *period length*. This number of samples between repeats corresponds to the note or the pitch produced by the 3rd Wave. The period length that the 3rd Wave uses is 1024 samples.

This is important because for the Wave Maker to analyze and convert audio into a wavetable with a 1024 sample period length, it is mathematically optimal to have an audio recording with a pitch of 93.75 Hz (MIDI note F#1).

When the 3rd Wave analyzes a recording, it will try to move the source audio's pitch to 93.75 Hertz or to 187.50 Hertz (one octave higher) in order to make the best wavetable it can. If the source audio has a single detectable pitch, the 3rd Wave's Wave Maker tool can shift that pitch to one of these two pitch frequencies.

The Wave Maker will look for areas in the source audio where the timbre changes and extract those to make the 64 waves that comprise the wavetable. If the timbre of the source audio changes only minimally, the extracted waveshapes will be very harmonically similar. If the timbre of the source audio changes dramatically over the length of the sample, the extracted waveshapes will be very harmonically different.

If you record noise or a sound that has either multiple pitches or no pitch at all, the 3rd Wave will still make a wavetable, but it may sound quite different than the source audio.

There are several things you can do to get the best results with the Wave Maker.

***For best results when making User wavetables:***

- Avoid effects on the source audio sample (reverb, chorus, phasing, etc.)
- If possible, when using pitched audio material such as a sample of an instrument, create the sample at a pitch of F#1 (93.75 Hz) — F# below middle C.
- If you are using non-pitched source audio such as noise, turn off the PITCH parameter in the Wave Maker before creating the wavetable.
- The audio source to be analyzed should be no longer than 20 seconds. Shorter is better.

## **Creating a Wavetable via the Audio In Jack**

It is quick and easy to create a wavetable by connecting an audio source to the AUDIO IN jack on the rear panel of the 3rd Wave.

***To create a wavetable via the Audio In jack:***

1. For simplicity, create a Basic Program by pressing the INIT PROG button from the home screen. (The Basic Init Program conveniently lets you use a Mod Wheel to sweep through the waveshapes in the active wavetable, which you will do to audition the user wavetable you create.)
2. In the Oscillator section, use the LEVEL knob to turn down the levels of Oscillator 2 and Oscillator 3. It is best to only hear Oscillator 1 for this example.
3. With an unbalanced, ¼-inch audio cable, connect an audio source to the AUDIO IN jack on the rear panel of the 3rd Wave.
4. Make sure the audio source is at an acceptable volume without distorting.
5. Press the MAKE WAVES button below the main display. The Wave Maker controls appear in the display.

6. If you are sample non-pitched material such as noise or percussion, turn soft knob 3 (PITCH) and set it to OFF.



The PITCH control tells the wave maker algorithm whether the signal has a mono pitch or should just be left alone from the pitch standpoint and not be corrected. With this control set to off, the pitch detection is ignored. Set PITCH to OFF for any non-pitch sound, or sounds with multiple pitches. Some sounds such as FM sounds that are atonal will not do as well with pitch correction on even if the source is technically a recording with a single pitch.

7. Press soft button 1 (ARM) then play the audio source. The maximum sample length is 20 seconds, but shorter audio samples will often result in better results. For best results, play the audio source/instrument's pitch at F#1.
8. When the source audio ends, the Wave Maker will display the sampled audio waveform.
9. Press soft button 2 (PLAY) to audition the sample and make sure it is what you intended. If its volume level is too low, adjust it on your audio source and repeat step 7.
10. If you want to adjust the start and end points in the sampled audio, use soft knob 1 and soft knob 2 to make these adjustments.
11. To adjust the sensitivity that determines where the Wave Maker looks for appropriate "waveform" points within the audio, adjust the Wave Sensitivity encoder with soft knob 4. The default setting of 0.125 is sensitive. Turning soft knob 4 clockwise results in less sensitivity and fewer timbral differences to extract waveforms (i.e. fewer dramatic timbral changes).
12. Press soft button 4 (MAKE TABLE). The Wave maker analyzes and creates a wavetable from the sampled audio.
13. To audition the new wavetable before saving it, go the Oscillator section and use the WAVETABLE knob to set Oscillator 1 to "WM" as its wavetable. This wavetable is the very last wavetable available (after the "A" set).
14. Hold down a note on the keyboard and move the Mod Wheel on your MIDI controller to sweep through the waves in the wavetable.
15. If you like what you hear, press the Make Waves button again to display the Wave Maker screen.
16. Press soft button 3 to save the wavetable.

17. In the screen that appears, use soft knob 3 and 4 to name the wavetable.
18. Use soft knob 2 to select a numbered location in the User set for the new wavetable.
19. Press soft button 4 (OK) to save the wavetable. The wavetable will now appear at the end of the “U” set along with the name you have given it. You can now use the Wave Envelope and other controls to sweep through the wavetable as you like.

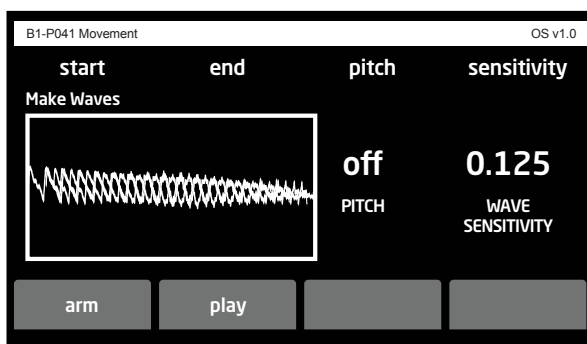

Make Wave controls

## Creating a Wavetable via USB

A second way to create a wavetable is to record a .wav file externally in advance and import it into the 3rd Wave over USB.

### ***To import audio via USB:***

1. For simplicity, create a Basic Program by pressing the INIT PROG button from the home screen. (The Basic Init Program conveniently lets you turn the Mod Wheel on your MIDI controller to sweep through the waveshapes in the active wavetable, which you will do to audition the user wavetable you create.)
2. With your computer and an audio recording application, create a mono-  
phonic, 96 kHz, 16-bit or 24-bit .wav file.
3. With a USB 2.0 cable, connect the 3rd Wave to your computer. The 3rd Wave will appear on your computer desktop. Double-click the 3rd Wave icon to open it. You will see several folders.
4. Drag the .wav file from your computer into the 3rd Wave folder called “Audio.”

5. On the 3rd Wave, press the GLOBAL button and use soft knob 1 to scroll to the READ WAVE MAKER WAVE FILE command.
6. Turn soft knob 2 (GO) clockwise. You will see the name of the .wav file.
7. Press soft button 4 (OK). The 3rd Wave imports the .wav file.
8. The Wave Maker screen appears in the display. The Wave Maker displays the imported .wav audio.
9. Press soft button 2 (PLAY) to audition the sample and make sure it is what you intended.
10. If you want to adjust the start and end points in the sampled audio, use soft knob 1 and soft knob 2 to make these adjustments.
11. To adjust the sensitivity that determines where the Wave Maker looks for appropriate “waveform” points within the audio, adjust the Wave Sensitivity encoder with soft knob 4. The default setting of 0.125 is sensitive. Turning soft knob 4 clockwise results in less sensitivity and fewer timbral differences to extract waveforms (i.e. fewer dramatic timbral changes).
12. Press soft button 4 (MAKE TABLE). The Wave maker analyzes and creates a wavetable from the sampled audio.
13. To audition the new wavetable before saving it, go the Oscillator section and use the WAVETABLE knob to set Oscillator 1 to “WM” as its wavetable. This wavetable is the very last wavetable available (after the “A” set).
14. Hold down a note on the keyboard and move the Mod Wheel on your MIDI controller to sweep through the waves in the wavetable.
15. If you like what you hear, press the Make Waves button again to display the Wave Maker screen.
16. Press soft button 3 to save the wavetable.
17. In the screen that appears, use soft knob 3 and 4 to name the wavetable.
18. Use soft knob 2 to select a numbered location in the User set for the new wavetable.
19. Press soft button 4 (OK) to save the wavetable. The wavetable will now appear at the end of the “U” set along with the name you have given it. You can now use the Wave Envelope and other controls to sweep through the wavetable as you like.

# Importing Wavetables into the “P” Set

With OS version 1.7 and higher, you can load your own wavetables into the “P” wavetable bank of the 3rd Wave, which represents the PPG format wavetables. Wavetables in this PPG format are simpler and have a grittier character than the high-resolution wavetables in the “User” wavetable bank.

By default, there are 36 wavetables in the “P” set. These are made up of the original 32 PPG wavetables from the PPG 2.2 and 2.3 as the first 32 locations in the “P” set. There are four additional wavetables: two custom wavetables in slots 32 and 33, then the original Prophet VS waves in slots 34 and 35 (with OS 1.7 and higher).

Because there are a total of 48 “P” wave slots available in total, you can add an additional 12 wavetables of your own and load them into slots P36-P47.



If you want, you can also overwrite any of the other factory “P” waves — though this will impact any presets that use them.

To create your own custom “P” wavetables you will use the Wave Maker to import a .wav file that is 8192 samples in length. The .wav file can be any sample rate from 24 kHz to 96 kHz at 16-bit, 24-bit, or 32-bit resolution. The essential requirement is that the .wave file must be exactly 8192 samples in length. The 3rd Wave will format the sample data to the correct bit depth and sample rate after your .wav file has been imported. First you need to import audio into the 3rd Wave.



There are two ways to do this:

- Use an audio recording application or DAW to create a total of 64 single-cycle waveforms that are 128 samples in length. A single-cycle waveform is a waveform that repeats after 128 samples and ends at sample 127 — near the same location where it started with sample 0. You will need 64 of these 128 sample length single-cycle waveforms arranged in a sequence. By using Audacity or other audio editing application, you can arrange the single-cycle waves back to back and save them as a .wav file. The more subtle the differences between each of the 64 single cycle waveforms, the smoother they will sound as the 3rd Wave sweeps through them. (For an example, listen to wavetable like P27 in the “P” set). In contrast, if you make each single-cycle waveform very different from each other, you will get very dramatic changes in timbre as the 3rd Wave sweeps through the wavetable. (For an example, listen to “Upper” wavetable P30 or the VS wavetables P34 and P35 in the “P” set). Save your sequence of waveforms into a .wav file and you can now import this .wav file to the 3rd Wave by copying it to the 3rd Wave’s AUDIO directory. See the steps directly below to import your .wav file to make your PPG format wavetable. Be aware that you must import a .wav file that is exactly 8192 samples in length:  $64 \times 128 = 8192$ .
- Use an audio recording application or DAW to create a monophonic .wav format audio file at any sample rate between 24 kHz to 96 kHz at 16-bit, 24-bit, or 32-bit resolution. You don’t need to create any single cycle waveforms using this technique. The wavetable will still be divided into individual segments every 128 samples and these will act as the waveforms. As a result, since this is simply dividing up the audio that has been provided, you will likely get discontinuities between the beginning and ending of each 128 sample segment, since they will not start and stop on the same sample. Make sure that you make a .wav file that is 8192 samples in length. The 3rd Wave will convert this audio to the correct sample rate and bit depth required for the “P” wavetable.

***To import a “P” wavetable from a .wav file you have created:***

1. Connect the 3rd Wave to your computer using a USB cable.
2. When the 3rd Wave appears on your desktop, double click its icon and drag the desired .wav file into the 3rd Wave’s AUDIO folder.
3. On the 3rd Wave, press the GLOBAL button and use soft knob 1 to scroll to the READ WAVEMAKER WAVE FILE command.
4. Turn soft knob 2 (GO) clockwise. You will see the name of the .wav file.

5. Press soft button 4 (OK). The 3rd Wave imports the .wav file.
6. The Wave Maker screen appears in the display with the imported .wav audio. If the .wav file is the correct 8192 samples in length, the display will say “PPG wavetable detected.”
7. Press soft button 4 (MAKE TABLE). The Wave maker creates a wavetable from the PPG format .wav file.
8. To audition the new wavetable before saving it, go the Oscillator section and use the WAVETABLE knob to set Oscillator 1 to “WM” as its wavetable. This wavetable is the very last wavetable available (after the “A” set).
9. Hold down a note on the keyboard and move the Mod Wheel on your MIDI controller to sweep through the waves in the wavetable.
10. If you select WM on one or more of the oscillators you will now hear the wavetable, and can view it by pressing the WAVE button.
11. Hold down a note on the keyboard and change the waveform offset on your oscillator or move the Mod Wheel on your MIDI controller to sweep through the waves in the wavetable if it is set to modulate the wave position.
12. If you like what you hear, press the Make Waves button again to display the Wave Maker screen.
13. Press soft button 3 to save the wavetable. The save location will be the first unused “P” location. This should be P36 if this is the first time you have tried this.
14. In the screen that appears, use soft knob 3 and 4 to name the wavetable.
15. Use soft knob 2 to select a numbered location in the “P” set for the new wavetable (if you don’t want to put it in the first un-used spot).
16. Press soft button 4 (OK) to save the wavetable. The wavetable will now appear at the location in the “P” set that you have selected along with the name you have given it. You can now use the Wave Envelope and other controls to sweep through the wavetable as you like.

# Importing Serum™ Wavetables

Xfer Serum is a wavetable synthesizer plug-in that creates high-quality wavetables using a visual interface. The 3rd Wave can directly import Serum™ wavetable .wav files and save them as custom User Wavetables.

## ***To import a Serum wavetable:***

1. Connect the 3rd Wave to your computer using a USB cable.
2. When the 3rd Wave appears on your desktop, double click its icon and drag the Serum wavetable .wav file into the 3rd Wave's AUDIO folder.
3. On the 3rd Wave, press the GLOBAL button and use soft knob 1 to scroll to the READ WAVEMAKER WAVE FILE command.
4. Turn soft knob 2 (GO) clockwise. You will see the name of the Serum .wav file.
5. Press soft button 4 (OK). The 3rd Wave imports the Serum .wav file.
6. The Wave Maker screen appears in the display. The Wave Maker displays the imported .wav audio. The display will say "Serum wavetable detected."
7. Press soft button 2 (PLAY) to audition the audio and make sure it is what you intended.
8. Press soft button 4 (MAKE TABLE). The Wave maker creates a wavetable from the Serum .wave file.
9. To audition the new wavetable before saving it, go the Oscillator section and use the WAVETABLE knob to set Oscillator 1 to "WM" as its wavetable. This wavetable is the very last wavetable available (after the "A" set).
10. Hold down a note on the keyboard and move the Mod Wheel on your MIDI controller to sweep through the waves in the wavetable.
11. If you like what you hear, press the Make Waves button again to display the Wave Maker screen.
12. Press soft button 3 to save the wavetable.
13. In the screen that appears, use soft knob 3 and 4 to name the wavetable.
14. Use soft knob 2 to select a numbered location in the User set for the new wavetable.

15. Press soft button 4 (OK) to save the wavetable. The wavetable will now appear at the end of the “U” set along with the name you have given it. You can now use the Wave Envelope and other controls to sweep through the wavetable as you like.

## Miscellaneous Settings

Miscellaneous settings apply to an individual program. In contrast, Global settings apply to the overall behavior of the 3rd Wave (and therefore *all* programs in the 3rd Wave).

- 1. Output routing:** The routing for the multi-parts to the 4 stereo output pairs on the back of the unit. See the section entitled “To assign multi-parts to individual rear-panel outputs” for a further explanation
- 2. Envelope Type:** Exponential or PPG Shape. The default is a modern exponential envelope shape. The PPG Shape is the shape and length as measured across two vintage PPG 2.2 and 2.3 units. The PPG envelope is still exponential in shape but more linear than a typical ADSR shape. It is also a lot longer for the same setting than a typical ADSR envelope.
- 3. Circuit Drift:** The amount of random fluctuation that is sent to the envelope times, the filter cutoffs, and the pitch of each oscillator. Range = 0 to 255. A well-calibrated vintage synthesizer will usually fall in the range of 33 to 72. Higher values dramatically affect the sound of programs, making them sound less “stable.” Used judiciously, Circuit Drift gives an organic feel to sounds and adds considerable movement and variation from voice to voice. A setting of 64 is a good place to start.
- 4. Free Running Oscillators:** On or off. By default, the virtual analog oscillators on the 3rd Wave restart their wave cycle each time you press a key. In Free-Running Oscillator mode, the virtual analog oscillators are continuously generating their waveshapes. This means that when you strike a key, the waveshape can be anywhere in its wave cycle — and not necessarily at its beginning. This can create a very “organic” sound which has subtle shifts in volume. Be aware that this feature only applies to the virtual analog oscillators (the “A” waves) and not the wavetables (the “P” and “U” waves).
- 5. Compressor:** Limiter that protects against clipping in the synthe-

sizer signal before going into the effect stage. If effects are off this is a final level limiter. The setting is either on or off, with a default to off for the Init program.

**6. Pitch Wheel /Bend Destination:** Modulation destination for the Pitch Wheel as a source. The default is to the oscillator frequency for all three oscillators. This can be set to any other destination, but the range is always calculated in semitones.

**7. Pitch Wheel Range Up:** 0 to 2 octaves in semitone steps.

**8. Pitch Wheel Range Down:** 0 to 2 octaves in semitone steps.

**9. MPE Voice Pitch Bend Range:** Range is from 2 to 8 octaves. This setting determines how wide a pitch bend range per voice the 3rd Wave responds to via an MPE-capable controller.

**10. MIDI MPE Y Config:** Unipolar or bipolar. This setting determines the Y-Axis mode and how the 3rd Wave responds to it when used with an MPE-capable controller.

**11. Velocity Strength:** Setting that determines the way the keyboard reacts to your playing velocity - 1. Velocity Off; 2. Light; 3. Medium; 4. Heavy; 5. Half 84; 6. Piano.

**12. Pressure Curve:** Setting that determines the way the keyboard reacts to your after touch pressure on the keyboard - 1. Off; 2. Normal; 3. Sparse; 4. Hard 2; 5. Hard 3; 6. Sparse 2; 7. Light; 8. Light 2; 9. Fatar Default.

**13. Glide Mode:** Fixed Rate or Fixed Time. Fixed Rate means that the speed at which the glide goes from note to note is the same. This rate is determined by the Glide Rate control. Since the speed is always the same, it will take less time to glide between two notes that are close to each other, and more time to travel the distance between two notes that are far from each other. Fixed Time means that it takes the same amount of time to glide between notes that are close to each other as it does for notes that are far from each other. This amount of time is also determined by the Glide Rate control, but in this case, the 0 to 127 range is setting the amount of time it takes to glide from note to note, and not the speed that is used to glide between notes.

**14. Glide Rate:** Speed of the glide or time to glide from note to note depending on the Glide mode setting - Range 0-127.

**15. Audio In Level to Filters:** You can connect an external audio signal to the 3rd Wave's rear-panel AUDIO IN 1 jack and process that audio through both filters and the dual effects of the 3rd Wave. This control sets the level of the external audio input. Range is from 0-127. (Note that this not a recording level for the Wave Maker.)

**16. Metronome:** The sound you will hear as a metronome when recording with the sequencer - 1. Off, 2. Pulse - Not Pitched, 3. Block, (wood block) - Pitched, 4. Noise - Non-Pitched pink noise.

**17. Metronome Volume:** Level of the metronome that you hear when you are recording with the sequencer - Range 0-127.

## Unison

When UNISON is on, the 3rd Wave behaves monophonically. However, monophonic notes can stack as many as 24 voices, depending on how many you choose to use (and how many multi-parts are active). Use Unison to create powerful basses, leads, and other sounds.

With Unison you can control how many voices to stack, the amount of detuning between the voices and what note has priority if you play more than one note on the keyboard. Unison can be set individually for each part in a multi-part program.

Unison has another useful feature — chord memory. Hold down a chord, press the Unison button, and the 3rd Wave will store that chord while in Unison mode. Single notes played on the keyboard will then trigger all notes of the stored chord, transposing them as you play up or down the keyboard. Use this feature to create chord stabs.

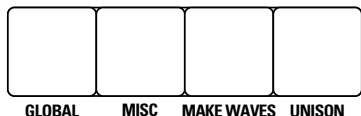

The Unison button

## Unison Parameters

Unison parameters are found in the main display. To see these, press the UNISON button on the front panel.



The Unison menu

**Unison:** On/Off — Enables and disables Unison.

**Voices:** 1-24 — Sets the number of voices stacked together.

**Detune:** 0-127 — Sets the amount of detuning between stacked voices.

**Key Assign:** Last, Low, high, last no retrigger, low no retrigger, high no retrigger — Determines what note has priority when more than one note is played on the keyboard (or via MIDI).

- Low-Note Priority gives priority to the lowest note played. Envelopes are not retriggered with each keystroke.
- Low Retrigger gives priority to the lowest note played but retriggers the envelopes with each keystroke.
- High Note and High Retrigger are similar to the low note settings, except that the highest note has priority.
- Last Note and Last Retrigger give priority to the last note played, either high or low.

**Legato:** On, Off, Slide — Enables and disables Legato mode. If Legato is on, holding a note and playing additional notes will not retrigger the envelopes (until you release the first note). If Legato slide is on, glide is not applied to individual notes, but only when you hold a note and play additional notes.

**Poly Count:** off, 2, 3, 4, 6, 8, 12 — Sets Poly Unison mode on. The number sets the polyphony (that is, how many notes you can play at one time). When set to OFF, Poly Unison mode is disabled.

***To use Unison:***

1. Press the UNISON button on the front panel.
2. In the display menu, use soft knob 2 to choose the number of voices to stack.
3. To detune the oscillators while in unison, use soft button 3 to set the amount of detuning between voices.

## Using Chord Memory

With Chord Memory, hold down a chord on the keyboard, press the UNISON button, and the 3rd Wave memorizes the notes of the chord. Single notes played on the keyboard will then trigger all notes of the stored chord, transposing them as you play up or down the keyboard.

If you save a program that uses chord memory, the chord is saved with the program. Unison can be set individually for each part in a multi-part program.

***To use chord memory:***

1. Hold down a chord on the keyboard.
2. Press the UNISON button. The chord voicing is memorized. Play a few notes to listen to the result.
3. If you save the program, the unison chord memory is saved with it.



### **To store a different chord in chord memory:**

1. Disable unison by turning off the UNISON button.
2. Hold down a different chord on the keyboard.
3. Press the UNISON button. The chord voicing is memorized. Play a few notes to hear the result.

### **To switch back to regular Unison mode:**

1. Disable unison by turning off the UNISON button.
2. Play a single note, and press the Unison button again.
3. Use soft button 2 to choose the number of voices you want to stack.

## **Polyphonic Unison Mode**

By default, when UNISON is on, the 3rd Wave behaves monophonically and can stack as many as 24 voices on a single note, depending on how many voices you choose to stack (and how many multi-parts are active).

Unison has a mode called “poly unison” in which you can play chords and set a specific number of notes you can play together. It will split up the voices automatically depending on how many notes you choose and the number of parts that are active.

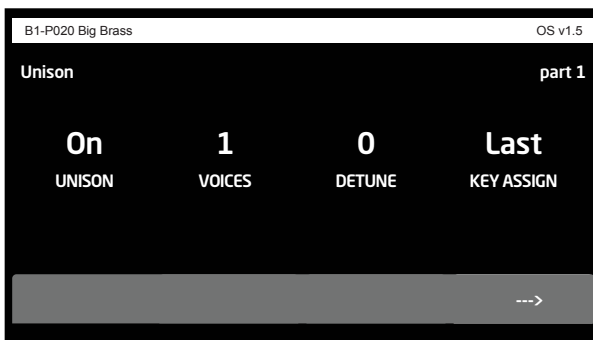

Page 1 of the Unison menu

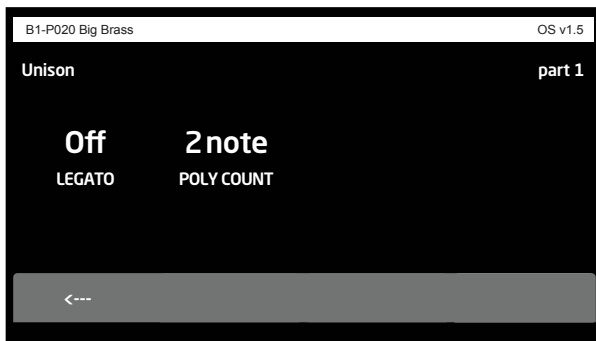

Page 2 of the Unison menu

**To use *Poly Unison mode*:**

1. Press the UNISON button on the front panel.
2. In the display menu, press soft button 4 (the arrow symbol) to show page 2 of the Unison menu.
3. Use soft button 2 (POLY COUNT) to set the polyphony. This will change the number of voices assigned per note. If you play more notes that can be allocated in poly unison, the 3rd Wave will allocate voices as available.

Note that when POLY COUNT is set to 0, Poly Unison mode is off and the active multi-parts will play monophonically (if in Unison mode).

# MIDI Program Change Messages

The 3rd Wave can send MIDI Program Change messages. When enabled in the GLOBAL menu, changing Banks or Programs on the 3rd Wave will change Banks and Programs on a MIDI instrument that supports MIDI Program Change messages and is connected to the 3rd Wave.

## ***To enable sending MIDI Program Changes on the 3rd Wave:***

1. With a MIDI cable, connect the MIDI OUT of the 3rd Wave to the MIDI IN of the desired MIDI instrument.
2. Enable RECEIVE MIDI PROGRAM CHANGES on the connected instrument.
3. On the 3rd Wave, press the GLOBALS button.
4. Use soft button 1 to locate the MIDI SEND PROGRAM CHANGE setting.
5. Use soft button 2 to set MIDI SEND PROGRAM CHANGE to ON.

Changing Banks or Programs on the 3rd Wave will now change Banks and Programs on the connected MIDI instrument.

## MPE Support

The 3rd Wave responds to MIDI Polyphonic Expression (MPE). Although the 3rd Wave doesn't output MPE from its own keyboard, you can connect an MPE-capable MIDI controller such as the Expressive E Osmose to control the 3rd Wave. This opens up a new realm of expressive possibilities including polyphonic pitch bends, filter sweeps, volume swells, and more.

## ***To enable MPE operation on the 3rd Wave:***

1. Press the GLOBALS button.
2. Use soft button 1 to scroll to the MIDI MPE MODE setting.
3. Use soft button 2 to set MIDI MPE MODE to ON.

**To set the 3rd Wave's MPE Pitch Bend range:**

1. Press the MISC button.
2. Use soft button 1 to scroll to the MPE VOICE PITCH BEND RANGE setting.
3. Use soft button 2 to set the desired pitch bend range.

**To set the MPE controller's Y-Axis Mode for the 3rd Wave:**

1. Press the MISC button.
2. Use soft button 1 to scroll to the MIDI MPE Y CONFIG setting.
3. Use soft button 2 to set the desired Y-Axis mode for the 3rd Wave. Choices are unipolar or bipolar.

In Unipolar mode, CC74 affects the destination by adding a range of 0-127. In Bipolar mode it adds a range of -63/+63 with 64 as the "0" point.

**To set the MPE controller's Y-Axis as mod source on the 3rd Wave:**

1. In the MODULATION section, press the SOURCE button.
2. Use soft button 1 to select a modulation slot.
3. Use soft button 2 to scroll to the MPE VOICE Y AXIS setting.
4. Use soft button 3 to select a mod destination (filter cutoff, for example).
5. Use soft button 4 to set a modulation amount.

Note that you can also use MPE Pitch Bend as a modulation source that you can route to any destination in the 3rd Wave's mod matrix.

**To set the MPE controller's Pitch Bend as mod source on the 3rd Wave:**

1. In the MODULATION section, press the SOURCE button.
2. Use soft button 1 to select a modulation slot.
3. Use soft button 2 to scroll to the MPE PITCH BEND setting.
4. Use soft button 3 to select a mod destination (filter cutoff, for example).
5. Use soft button 4 to set a modulation amount.

# Global Settings

Global settings apply to all programs in the 3rd Wave. In other words, these settings apply to the overall behavior of the 3rd Wave. These include such things as keyboard velocity curves, MIDI settings, and more.

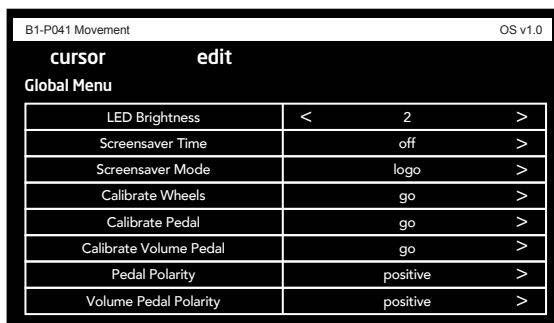

Global Menu	
LED Brightness	< 2 >
Screensaver Time	off >
Screensaver Mode	logo >
Calibrate Wheels	go >
Calibrate Pedal	go >
Calibrate Volume Pedal	go >
Pedal Polarity	positive >
Volume Pedal Polarity	positive >

The Global Menu

## **To use the GLOBAL menu:**

1. Press the GLOBAL button.
2. Use soft button 1 to scroll through the list of parameters.
3. To set a selected parameter, turn soft button 2, as necessary.

## Global Menu Parameters

**1. LED Brightness:** 1...4 — Controls brightness of the various LEDs on the 3rd Wave front panel.

**2. Display Brightness:** high, medium, low — Controls brightness of the main display.

**3. Accessibility Light Sensitivity:** off, on — When off, button LEDs blink normally. When on, LEDs do not blink to accommodate users sensitive to blinking lights.

**4. Metronome in Headphone Only:** off, on — When off, the Sequencer's metronome is audible in both the main outputs as well as the headphone outputs. When on, the Sequencer's metronome is audible only in the headphone output.

**5. Pot Mode:** Jump, Passthru — The rotary controls on the 3rd Wave’s front panel are a mixture of “endless” rotary encoders and potentiometers or “pots.” The pots are identifiable by their lined knobs and limited amount of travel. There are two Pot modes to determine how the synth reacts when the programmable parameters are edited. (Master volume is not programmable, so these modes don’t apply.)

JUMP mode uses an absolute value based upon the position of the pot when edited: turn a pot and the value jumps immediately from the stored value to the edited value.

In PASSTHRU mode, turning the pot has no effect until after the edited value equals the preset value (that is, until the edited value “passes through” the stored value).

**6. Screensaver Time:** Off...5 minutes, 1 minutes, 30 seconds — Dims the main display after the specified time. This can help prolong the life of the display over time.

**7. Screensaver Mode:** Logo, Blank — When the display is dimmed this selects what is shown on screen.

**8. Calibrate Wheels** — Calibrates the Pitch and Mod wheels. Execute this command and follow the on-screen directions.

**9. Calibrate Pedal** — Calibrates an expression pedal connected to the rear-panel PEDAL/IN 2 jack. Execute this command and follow the on-screen directions.

**10. Calibrate Volume Pedal** — Calibrates a sustain pedal connected to the rear-panel VOLUME jack. Execute this command and follow the on-screen directions.

**11. Pedal Polarity:** Positive, Negative — There are two types of pedals, normally open and normally closed. Either type can be used with the Sustain switch input. This setting allows you to accommodate both models in case yours behaves in a way that is the opposite of what you expect due to its polarity. Connect your pedal to the rear-panel PEDAL/IN 2 jack and choose the appropriate setting based on its behavior.

**12. Volume Pedal Polarity:** Positive, Negative — There are two types of pedals, normally open and normally closed. Either type can be used with the Sustain switch input. This setting allows you to accommodate both models in case yours behaves in a way that is the opposite of what you expect due to its polarity. Connect your pedal the rear-panel VOLUME jack and choose the appropriate setting based on its behavior.

**13. Sustain Footswitch:** Pressed Closed, Pressed Open — There are two types of momentary footswitches, normally open and normally closed. Either type can be used with the rear-panel SUSTAIN pedal input. This setting allows you to accommodate both models in case yours behaves in a way that is the opposite of what you expect due to its polarity. (Sustain is on until the footswitch is pressed and then it turns off, which is the opposite of the expected behavior.) Connect your pedal and choose the appropriate setting based on its behavior.

**14. MIDI In Channel:** All, 1...16 — Selects which MIDI channel receives MIDI data, 1 to 16. Choosing ALL receives on all 16 channels.

**15. MIDI Out Channel:** All, 1...16 — Selects which MIDI channel sends MIDI data, 1 to 16. Choosing ALL sends on all 16 channels.

**16. MIDI Local Control:** On, Off — When on (the default), the keyboard and front panel controls directly affect the 3rd Wave. When off, the controls are transmitted via MIDI but do not directly affect the “local” synth (that is, the 3rd Wave). This is primarily useful for avoiding MIDI data loops that can occur with some external Sequencers.

**17. MIDI In Cable:** usb+midi, usb, midi — Sets the port (MIDI or USB) by which MIDI and MIDI clock are received.

**18. MIDI Out Cable:** usb+midi, usb, midi — Sets the port (MIDI or USB) by which MIDI and MIDI clock are sent.

**19. MIDI Send Arp Notes:** off, on — When On, the Arpeggiator outputs MIDI note numbers. You can use this feature to drive other MIDI-equipped devices such as synthesizers and drum machines.

**20. MIDI Send Program Change:** off, on — When on, changing Banks or Programs on the 3rd Wave will change Banks and Programs on a MIDI instrument that supports MIDI Program Change messages and is connected to the 3rd Wave.

**21. MIDI Multitimbral Mode:** On, Off — This mode allows independent MIDI control of multi-parts 1-4 on a given program. When MIDI Multitimbral mode is on, each multi-part responds to a MIDI data on a specific MIDI channel. For example, if you set multi-part 1 to MIDI channel 1, it will respond to MIDI channel 1. This allows you to control each multi-part separately via an external device such as sequencer or MIDI controller.

**22. MIDI Multitimbral Channel Part 1:** 1-16 — This sets the MIDI channel to which multi-part 1 responds. For example, if you set MIDI Multitimbral Channel Part 1 to MIDI channel 1, it will respond to MIDI channel 1.

**23. MIDI Multitimbral Channel Part 2:** 1-16 — This sets the MIDI channel to which multi-part 2 responds. For example, if you set MIDI Multitimbral Channel Part 2 to MIDI channel 1, it will respond to MIDI channel 1.

**24. MIDI Multitimbral Channel Part 3:** 1-16 — This sets the MIDI channel to which multi-part 3 responds. For example, if you set MIDI Multitimbral Channel Part 3 to MIDI channel 1, it will respond to MIDI channel 1.

**25. MIDI Multitimbral Channel Part 4:** 1-16 — This sets the MIDI channel to which multi-part 4 responds. For example, if you set MIDI Multitimbral Channel Part 4 to MIDI channel 1, it will respond to MIDI channel 1.

**26. MIDI Sysex Enable:** On, Off — Sets whether MIDI System Exclusive data is received or ignored.

**27. MIDI Param Send:** Off, CC, NRPN — Changes to the values of front panel controls are transmitted via MIDI as Non-registered Parameter Number (NRPN) controllers or as Continuous Controllers (CC). Transmission of parameters can also be turned off.

**28. MIDI Param Receive:** Off, CC, NRPN — Sets the method by which parameter changes are received via MIDI. As with transmission, NRPNs are the preferred method.



**29. MIDI Clock Mode:** Sets the 3rd Wave's mode of sending and receiving MIDI clock messages:

- OFF: MIDI Clock is neither sent nor received.
- OUT: MIDI Clock is sent, but not received.
- IN: MIDI Clock is received, but not sent.
- IN-TEMPO-SYNC: MIDI Clock is received and synth synchronizes with BPM only, it does not synchronize to the downbeat.

**30. MIDI Start/Stop Sequence:** On, Off — When on, the 3rd Wave's Sequencer will be triggered to play and stop via external MIDI command. The external MIDI must be connected to the rear-panel MIDI or USB ports and MIDI Channel set appropriately.

**31. MIDI MPE Mode:** off, on — When on, the 3rd Wave responds to MIDI Polyphonic Expression (MPE).

**32. Export Program** — Exports the current program to the PROGRAM directory (folder) on the 3rd Wave. Connect the 3rd Wave to a computer, then click on the 3rd Wave icon on your desktop to access this folder. You can then copy any exported programs to your computer to archive them.

**33. Import Program** — Imports a program from the 3rd Wave's PROGRAM directory (folder) into the currently selected program slot. To place a program in this directory, connect the 3rd Wave to a computer, then click on the 3rd Wave icon on your desktop and locate the PROGRAM folder. You can then copy any 3rd Wave program that you have saved or archived into the PROGRAM folder. After you have copied a program file, press the GLOBAL button. Then use soft knob 1 to scroll to the IMPORT PROGRAM command and use soft knob 2 (GO) to execute the command and import the program. Press the WRITE button twice to save the program on the 3rd Wave. Importing a single program only loads it into the edit buffer in memory. Writing the program will save it so it is available after restarting the synth.

**34. Bulk Program Export** — Exports a selected bank of programs to the PROGRAM directory (folder) on the 3rd Wave. Connect the 3rd Wave to a computer, then click on the 3rd Wave icon on your desktop to access this folder. You can then copy any exported programs to your computer to archive them.

**35. Bulk Program Import** — Imports all programs currently in the PROGRAM directory (folder) on the 3rd Wave. Connect the 3rd Wave to a computer, then click on the 3rd Wave icon on your desktop to access this folder. You can then copy any 3rd Wave programs that you have saved or archived into the PROGRAM folder. After you have copied any program files press the GLOBAL button. Then use the soft knobs to select the destination (the starting point in the banks and programs for the import). Use soft knob 2 (GO) to execute the command and import the programs. The imported programs will overwrite any previous programs in those locations. The order of the programs will be based on the file names in alphabetical order.

**36. Export Wavetable** — Exports a wavetable of your choice to the WAVES directory (folder) on the 3rd Wave. Connect the 3rd Wave to a computer, then click on the 3rd Wave icon on your desktop to access this folder. You can then copy any exported wavetables to your computer to archive them.

**37. Import Wavetable** — Imports a wavetable from the WAVES directory (folder) into the 3rd Wave. Connect the 3rd Wave to a computer, then click on the 3rd Wave icon on your desktop to access this folder. You can then copy any 3rd Wave compatible wavetable file (our own custom format ending with extension .wt) from your computer into the WAVES folder. After you have copied a wavetable press the GLOBAL button. Then use the soft knobs to select the destination. Execute the command and import the wavetable.

**38. Bulk Wavetable Import** — Imports all wavetables currently in the WAVES directory (folder) on the 3rd Wave. Connect the 3rd Wave to a computer, then click on the 3rd Wave icon on your desktop to access this folder. You can then copy any 3rd Wave compatible wavetable file (our own custom format ending with extension .wt) from your computer into the WAVES folder. After you have copied the wavetables, press the GLOBAL button. Then use the soft knobs to select the destination (the starting point in the “P” and “U” wavetable sets). Execute the command and import the wavetables. The imported wavetables will overwrite any wavetables in those locations. For this reason you should back up your factory wave-tables first, using the EXPORT WAVETABLE command.

**39. Edit Wavetable Names** — Use this command to rename any wavetables in the “P” or “U” wavetable sets.

**40. Tune Filters** — Tunes and recalibrates the analog low-pass filters. You shouldn't have to do this in most circumstances since the filters are pre-calibrated and generally don't require re-calibration or re-tuning.

**41. Firmware Update** — Allows you to update the 3rd Wave's OS if necessary by importing a new OS from the 3rd Wave's `FIRMWARE` directory (folder). To install an OS update, download the update from the Groove Synthesis website, then connect the 3rd Wave to your computer. Next, click on the 3rd Wave icon on your desktop and locate the `FIRMWARE` folder. You can then copy the new OS firmware into the `FIRMWARE` folder. After you have copied a program file, press the `GLOBAL` button. Then use soft knob 1 to scroll to the `FIRMWARE UPDATE` command and use soft knob 2 (`GO`) to execute the command and update the OS. Follow the on-screen instructions, and when finished restart the synthesizer.

**42. Analog Filter Bypass** — Bypasses the analog filters when set to "on" (that is, bypass is on). In this mode, the digital State-Variable filter is still active.

**43. Export Device Image** — This command is used to archive the current state of the 3rd Wave and all of its data. You shouldn't need to use it under normal circumstances.

**44. Import Device Image** — This command is used to restore the 3rd Wave to a previously archived state, if necessary. You shouldn't need to use it under normal circumstances.

**45. Read WaveMaker WAV file** — This command is used to import a 3rd Wave compatible .wav file (96 kHz, 16-bit or 24-bit, mono .wav format) into the Wave Maker tool. See "Creating Custom Wavetables" on page 82 for detailed instructions on how to use this.

**46. Functions Test** — This command is used for internal testing and development. You shouldn't need to use it under normal circumstances.

**47. Controls Test** — This command is used for internal testing and development. You shouldn't need to use it under normal circumstance

**48. Bootloader Update** — This command is used for technical support. You shouldn't need to use it under normal circumstances.

# How to Sound Like a Vintage PPG

Although the 3rd Wave can sound very much like a PPG due to the way it is designed, there are several things you can do to make it sound even more like an authentic vintage PPG.

## Choose the Right Wavetable

The original PPG 2.2 and 2.3 both used 8-bit wavetables that had 64 symmetric single-cycle waves in them. These 31 wavetables are wavetables P00 to P30 in the 3rd Wave. The wavetables above P30 that have a “P” in front of the name are also 8-bit tables, but they aren’t tables that were parts of the original PPG.

If you use one or more of the P00 to P30 wavetables in a preset, is that enough to make the 3rd Wave sound like a PPG? The short answer is “no.” The fact is, there are several other things that you need to do to make a preset sound like a classic PPG. Some of these things are built-in features. For example, the PPGs ran at a high sample rate that was a division of the clock rate that the processor ran at. The 3rd Wave runs at that same rate when you select a “P” wavetable. But you also need the waveforms to be “calculated” a certain way without smoothing or any reconstruction filter. To do this, you will need to look at the three items in the WaveFlow display.

## Choose the Right Wave Flow Settings

To operate like a PPG, press the `WAVE FLOW` button and turn on “Use Upper Wavetable,” turn off “Waveform Smoothing,” and turn off “Wavetable Smoothing.” For a complete explanation of what these three buttons do, refer to “About Wave Flow” on page 18. In short, the PPG did not have interpolation when changing from one waveform in a wavetable to another. Also, it did not have interpolation when changing from one pitch or note to another. Finally, it would not stop at the highest waveform in a given wavetable if you modulated past the last position in the wavetable, but rather it kept going into wavetable P30 which is the “upper wavetable.” Using these three settings, you are most of the way to making the 3rd Wave sound like a PPG.

## Choose the Right Envelope Settings

The next thing you will need to do is switch to the envelope shapes that were used in the PPG. You can do this by pushing the “Misc” button below the main display. This miscellaneous section holds parameters that can be saved and changed per patch.

The second parameter, “Envelope Type” allows you to change the 3rd Wave’s envelopes from “Exponential” to “PPG Shape.” The general shape of the PPG envelopes is less exponentially curved than new synthesizers. They were also designed to have longer attack, decay, and release times than most other synthesizers.

## Use “Key to Waves”

The PPG also had controls that allowed things to change as you moved from the bottom to the top of the keyboard range. First is the PPG’s “KW” control. This abbreviation stood for Key to Waves, and determined which note on the keyboard played which waveform in the wavetable. The PPG provided 8 settings for KW (0-7). Since there are 64 waveforms and 61 notes on the keyboard, you can make the keyboard play a different waveform offset in the wavetable on each note.

On the PPG this meant setting this control to a value of 4. If you go above this on the PPG, you could actually skip more than one waveform per note. On the 3rd Wave, all three oscillators have the “Key To Waves” parameter. The main difference is that on the 3rd Wave, the parameter has 128 settings (0-127). It does the same things as the KW parameter on the PPG.

It is important to note that the way the PPG implemented the “Key To Waves” function was actually in reverse key order and in reverse order relative to the wavetable. So to be faithful to the PPG KW (key to wave) control, make sure you set the `KEY TO WAVE REVERSE` parameter to `ON` (press soft button 2), so that the highest offset of the wavetable appears at the bottom of the keyboard range and the lowest offset of the wavetable appears at the top of the keyboard range.

If you want a different waveform per note starting with 63 in the wavetable and have the next lower offset in the wavetable play with each higher note, then, just like the PPG, set the Key To Waves to the half way

point of 64 and set KEY TO WAVE REVERSE parameter to ON, which is equivalent to the PPG KW setting of 4. Many PPG Patches used this feature instead of sweeping the waveforms in a wavetable to create movement.

### **Use “Key to Filter” and “Key to Loudness”**

On the PPG, there was also a KF and a KL control with 8 settings each. KF stood for “Key to Filter.” This controlled filter tracking across the span of the keyboard from high to low. Generally speaking, the higher the note pressed, the wider the filter opened, making higher notes sound “brighter.” This is common to many synthesizers today.

On the 3rd Wave, this corresponds to the “Key Amount” control found on both of the filters. On the PPG, a setting of 0 did nothing. A setting 3 on the PPG meant the filter cutoff changed by an octave as you played octave higher on the keyboard. On the 3rd Wave, this corresponds to a parameter value of 63 out of 127. A value of 7 on the PPG corresponded to two octaves of change to the cutoff for each octave on the keyboard. On the 3rd Wave a Key Amount setting of 127 have the same effect.

The KL control stood for “Key to Loudness.” Generally speaking, the higher the note pressed, the louder the sound — but this effect was subtle. On the PPG, KL = 0 meant that the lowest note on the keyboard was the loudest and the volume was scaled down as you went up the keyboard to a very low volume at the top. KL = 7 meant the highest note was the loudest and the scaling traveled down the keyboard until the note volume was very low towards the bottom of the keyboard.

Also on the PPG, KL = 4 meant no scaling and equal volume across the keyboard. Many PPG patches had this setting at something less than 4 to keep the waveform volume and the aliasing in check as you played in the top couple of octaves.

On the 3rd Wave, this is controlled by choosing Note Number as a modulation source, and choosing Oscillator Level All as the modulation destination. Set the Modulation Amount to -64 to make higher notes lower in volume, which is likely to be needed to match a classic PPG sound. Conversely set the Modulation Amount to +64 to make higher notes louder.

## Use “Upper Wavetable”

The other factor is the Upper Wavetable. The PPG had a “UW” control that stood for “Upper Wavetable.” It had the effect of using the upper wavetable waveforms, (which are the varied set of waveforms found in wavetable P30), if you modulated past the end of a selected wavetable in the PPG.

On the 3rd Wave, this setting is found in the Wave Flow menu (press the Wave Flow button). If you set “Use Upper Wavetable” to “off” on the 3rd Wave, wave sweeping will always stop at offset 59 for the “P” wavetables. This is due to the fact that the last 4 waveforms in all of the “P” wavetables are always triangle, pulse, square, and sawtooth as they were in the PPG. These are 8-bit and operate with the same lack of filtering as the rest of the wavetable. To hear these last four positions, turn on the USE UPPER WAVETABLE. They are great for lo-fi emulations of analog waveforms, but for high-fidelity “analog” subtractive synthesis, use the waveforms in the set of “A” waves.

What did the upper wavetable and the UW on/off switch do on the PPG? Two things. First the upper wavetable was always loaded in memory whether the UW control on the PPG was on or off. This meant that if you were at a particular offset in a wavetable and had an envelope or other modulation set so that the you went past the end of the last position, you would go right into this upper wavetable (P30) as far as the modulation carried you (up to the full 64 positions if necessary).

Second, on the PPG you could make a stacked patch by creating two different patches between what was called Group A and Group B. Any patch would hold two different patches, one in A and one in B. They could both be played at the same time if you used keyboard mode 1, which gave you a stack that reduced polyphony to 4 notes. The problem was that you had to use the same wavetable for both patches. So if you selected wavetable 04, for example, it would use wavetable 04 for both Group A and Group B. Your stack would be two different patches, but both would use the same wavetable. The UW control let you get around this by assigning wavetable 30, which was the “upper wavetable,” to the Group A patch, and whatever wavetable you selected on the display, (wavetable 04, for example), to the Group B patch. This was the only way to create a stack with patches that used two different wavetables.

Group B could be any wavetable that you selected, but Group A would always be wavetable 30.

The 3rd Wave allows up to 4 multi-parts/sounds simultaneously, so it is easy to create this effect by assigning two different “P” wavetables to multi-part 1 and multi-part 2 (Group A and Group B on the PPG, respectively).

### **Use Just Two Oscillators and Detune Them**

The last thing to remember is that the PPG had only 2 oscillators per voice — unlike the 3rd Wave which has 3 oscillators per voice. Also, on the PPG, both oscillators had to use the same wavetable. So, even though the 3rd Wave allows you to choose a different wavetable for each of its three oscillators, to be authentic, use only two oscillators and choose the same wavetable on both oscillators. If this sounds limiting, you can always set the wave offset differently on each oscillator. For instance, Oscillator 1 can have an offset of 2 on a given wavetable and oscillator 2 can have an offset of 14. This is what allowed PPG sounds to have more variety even though they had to use the same wavetable.

Don't forget to detune the two oscillators in order to sound authentic. Look at some of the factory patches in the 3rd Wave that are recreations of PPG presets. A common technique is to set the Fine control of Oscillator 1 to -3 and the Fine control of Oscillator 2 to +3. On the PPG, this was equivalent to a Detune setting of 2 in the Tuning section. Some of the original PPG programs went much further than this, so don't be afraid to go further.

### **Use “Circuit Drift”**

Finally, use the `CIRCUIT DRIFT` parameter in the 3rd Wave's `MISC` menu to add voice-to-voice micro-variations in oscillator pitch, envelope times, cutoff frequencies, and other parameters. This gives an organic feel with considerable movement. A setting of 64 is a good place to start.



# Troubleshooting the 3rd Wave

The 3rd Wave is built to provide you with many years of musical inspiration. However, if you encounter a problem, or if your 3rd Wave seems to be behaving in unexpected ways, here are some common solutions.

## ***If the 3rd Wave isn't making sound:***

1. Create an Init Program. (GLOBAL>SET INIT PROGRAM>Go)
2. If the problem persists, check the following:
  - Make sure the VOLUME control is set to an appropriate value
  - Make sure audio cables are connected to MAIN STEREO OUTPUT 1 jacks (left and right).
  - In the GLOBAL menu, make sure that MIDI LOCAL CONTROL is set to ON.

## ***If the sequencer or arpeggiator won't start:***

- Make sure MIDI CLOCK MODE in the GLOBAL menu is set to OUT or OFF. Or if MIDI CLOCK MODE is set to IN, make sure the 3rd Wave is receiving MIDI clock from an external device.

## ***If there is a hum in the audio output:***

- This can occur from USB-caused ground loops. If your 3rd Wave is connected to a computer via USB, resolve any grounding issues or use MIDI instead of USB. (MIDI is opto-isolated.)

## ***If the 3rd Wave is behaving erratically:***

- This can be caused by a MIDI feedback loop. Disconnect all 3rd Wave MIDI connections (MIDI and USB cables) and see if the problem persists. You can also monitor the MIDI traffic with *MIDI Monitor* (Mac OS) or *MIDI-OX* (Windows) to see if the 3rd Wave is being over-run with duplicate messages.

## ***If the 3rd Wave doesn't respond to its controls:***

- Make sure MIDI LOCAL CONTROL is ON in the GLOBAL menu.

## ***If the filters sound unusual:***

- You may need to recalibrate the filters. See “Calibrating the Filters” on page 115.

## Contacting Technical Support

If you are still having a problem with the 3rd Wave, contact Technical Support at [support@groovesynthesis.com](mailto:support@groovesynthesis.com). Please include the purchase date of your 3rd Wave, its serial number, and the operating system version. The OS version is shown at the upper left of the main display.

## Warranty and Repairs

Groove Synthesis provides a 2 year warranty on parts and labor for the 3rd Wave from its date of purchase when purchased directly from Groove Synthesis.

If your 3rd Wave needs to be repaired, please contact:

[support@groovesynthesis.com](mailto:support@groovesynthesis.com).

Please do not return the 3rd Wave to Groove Synthesis without first obtaining a return authorization (RA) number. To obtain an RA number, email technical support and provide the following:

- Your 3rd Wave's serial number
- Your name
- Your address
- Your email address
- Your phone number
- The date you purchased the 3rd Wave

If you need to return your 3rd Wave for repair, you must ship it to Groove Synthesis. We recommend insuring it and packing in the original packaging. If the 3rd Wave is damaged during shipping because of insufficient packaging, the warranty will not cover this.

# Calibrating the 3rd Wave

If you experience unexpected behavior with the filters, you can calibrate them in the Global menu.

## Calibrating the Filters

**To calibrate the filters:**

1. Press the GLOBAL button.
2. Use soft knob 1 to scroll to the TUNE FILTERS command.
3. Turn soft knob 2 to select GO.
4. When the TUNE FILTERS screen appears, press soft button 4 (OK). The 3rd Wave performs its auto-calibration procedure. Don't turn off the power during this procedure.
5. When finished, turn any knob to return to the current program and play the 3rd Wave again.

## Updating the 3rd Wave OS

Occasionally Groove Synthesis provides updates to the 3rd Wave OS with feature enhancements and bug fixes. To update your 3rd Wave to the latest OS, connect the 3rd Wave to a computer via USB, and copy the new OS file to the FIRMWARE directory (folder) on the 3rd Wave as explained below.

## Checking Your Operating System Version

If you've just purchased your 3rd Wave new, the latest operating system may already be installed. Be sure to check the Support page of the Groove Synthesis website occasionally check for the latest version. It may include new features and enhancements that you would like to use.

To update your 3rd Wave OS, you'll need a computer and a USB cable. To download the latest version of the 3rd Wave OS along with instructions on how to perform a system update, visit the Groove Synthesis website at:

<https://www.groovesynthesis.com/support/>

**To check your OS version:**

1. Turn on your 3rd Wave. The OS version number is displayed in the upper right corner of the display.
2. If your OS is out of date, download the latest version from the Support page of the Groove Synthesis website and update your instrument using the instructions included with the download.

**To update your 3rd Wave's operating system:**

1. Download the new OS from the Support page of the Groove Synthesis website. The file type is "ldr" for the OS.
2. Connect the 3rd Wave to your computer using the USB connector on the back of the synth.
3. Once connected, the 3rd Wave will show up on your computer desktop as an external drive.
4. Copy the "ldr" file into the FIRMWARE folder on the 3rd Wave.
5. Once the file has finished copying, press the GLOBAL button on the 3rd Wave, then use soft knob 1 to locate the "Firmware Update" command.
6. Use soft knob 2 to select GO.
7. Press soft button 1 (REFRESH). The screen displays the name of the OS file that you copied to the FIRMWARE folder.
8. Eject the 3rd Wave icon from your computer desktop.
9. Disconnect the USB cable from the back of the 3rd Wave.
10. Press soft button 4 (OK). The display will alert you when the OS has finished updating.
11. Once the display indicates that it is finished, turn off the synthesizer briefly then turn it back on again. The updated OS version appears in the upper right corner of the display.

# Exporting Programs

You can use the `EXPORT PROGRAM` and `BULK PROGRAM EXPORT` commands in the `GLOBAL` menu to transmit a single program or an entire bank of 3rd Wave sounds to the `PROGRAMS` directory (folder) on the 3rd Wave. If you then connect the 3rd Wave to a computer, you can then copy any exported programs to the computer to archive them.

## ***To export a single program:***

1. Connect the 3rd Wave to a computer using a USB cable.
2. Press the `GLOBAL` button on the 3rd Wave.
3. Use soft knob 1 to select the `EXPORT PROGRAM` command.
4. Use soft knob 1 to choose `GO`. The program is exported to the `PROGRAMS` directory of the 3rd Wave.
5. Double-click on the 3rd Wave icon on your computer desktop and locate the `PROGRAMS` folder. You can then copy the exported 3rd Wave program to your computer to archive it.
6. When finished, turn any knob to return to the current program and play the 3rd Wave again.

## ***To export an entire bank of programs:***

1. Connect the 3rd Wave to a computer using a USB cable.
2. Press the `GLOBAL` button on the 3rd Wave.
3. Use soft knob 1 to select the `BULK PROGRAM EXPORT` command.
4. Use soft knob 1 to choose `GO`.
5. In the `BULK PROGRAM EXPORT` screen, use soft knob 1 to select that bank you want to export.
6. Press soft button 4 (`OK`). The programs are exported to the `PROGRAMS` directory of the 3rd Wave.
7. Double-click on the 3rd Wave icon on your computer desktop and locate the `PROGRAMS` folder. You can then copy the exported 3rd Wave programs to your computer to archive them.
8. When finished, turn any knob to return to the current program and play the 3rd Wave again.

# Importing Programs

If you connect the 3rd Wave to a computer via USB, you can copy any previously archived programs to the PROGRAMS directory (folder) on the 3rd Wave. You can then use the IMPORT PROGRAM and BULK PROGRAM IMPORT commands in the GLOBAL menu to import and use the sounds. The imported programs will overwrite any previous programs in the selected destination.

## ***To import a single program:***

1. Connect the 3rd Wave to a computer using a USB cable.
2. Double-click on the 3rd Wave icon on your computer desktop and locate the PROGRAMS folder.
3. On your computer, locate the 3rd Wave program you want to import and drag it into the PROGRAMS folder of the 3rd Wave.
4. Press the GLOBAL button on the 3rd Wave.
5. Use soft knob 1 to select the IMPORT PROGRAM command.
6. Use soft knob 2 to choose GO.
7. In the screen that appears, use soft knob 1 to choose the destination bank, then use soft knob 2 to choose the destination program slot.
8. Press soft button 4 (OK). The program is copied to the chosen bank and program location.

## ***To import an entire bank of programs:***

1. Connect the 3rd Wave to a computer using a USB cable.
2. Double-click on the 3rd Wave icon on your computer desktop and locate the PROGRAMS folder.
3. On your computer, locate the 3rd Wave program you want to import and drag it into the PROGRAMS folder of the 3rd Wave. Make sure only the files you want to import are in the PROGRAMS folder. Remove any other files that may be there.
4. Press the GLOBAL button on the 3rd Wave.
5. Use soft knob 1 to select the BULK PROGRAM IMPORT command.

6. Use soft knob 2 to choose GO.
7. In the screen that appears, use soft knob 1 to choose the destination bank, and soft knob 2 to choose the beginning program slot where the programs will load. The programs will then load sequentially into the 3rd Wave starting from the bank and program location you have chosen.
8. Press soft button 4 (OK). The programs are copied to the 3rd Wave.



©2024 Groove Synthesis LLC  
[www.groovesynthesis.com](http://www.groovesynthesis.com)